

## Introduction

The Xilinx LogiCORE™ IP Complex Multiplier implements high-performance, optimized complex multipliers based on user-specified options.

All operands and the results are represented in signed two's complement format. The operand widths and the result width are parameterizable.

## Features

- Drop-in module for Kintex™-7, Virtex®-7, Virtex®-6, Virtex-5, Virtex-4, Spartan®-6, Spartan-3/XA, Spartan-3E/XA, and Spartan-3A/3AN/3A DSP/XA FPGAs
- 8-bit to 63-bit input precision and up to 127-bit output precision
- Supports truncation or unbiased rounding
- Configurable latency
- 3 or 4 real multiplier implementation options
- Option to use LUTs or embedded multipliers/XtremeDSP™ slices
- Resource estimation in the Xilinx CORE Generator™ graphical user interface (GUI)
- For use with Xilinx CORE Generator and Xilinx System Generator for DSP v13.1

LogiCORE IP Facts Table					
Core Specifics					
Supported Device Family <sup>(1)</sup>	Virtex-7 and Kintex-7, Virtex-6, Virtex-5, Virtex-4, Spartan-6, Spartan-3/XA, Spartan-3E/XA, Spartan-3A/3AN/3A DSP/XA				
Supported User Interfaces	Not Applicable				
	Resources <sup>(2)</sup>				Frequency
Configuration	LUTs	FFs	DSP Slices	Block RAMs <sup>(3)</sup>	Max. Freq. <sup>(4)</sup>
16x16, resource optimized	32	64	3	0	450 MHz
Provided with Core					
Documentation	Product Specification				
Design Files	Netlist				
Example Design	Not Provided				
Test Bench	Not Provided				
Constraints File	Not Applicable				
Simulation Model	VHDL behavioral model in the xilinxcorelib library VHDL UniSim structural model Verilog UniSim structural model				
Tested Design Tools					
Design Entry Tools	CORE Generator tool 13.1 System Generator for DSP 13.1				
Simulation	Mentor Graphics ModelSim 6.6d Cadence Incisive Enterprise Simulator (IES) 10.2 Synopsys VCS and VCS MX 2010.06 ISIM 13.1				
Synthesis Tools	N/A				
Support					
Provided by Xilinx, Inc.					

1. For a complete listing of supported devices, see the [release notes](#) for this core.
2. Resources listed here are for Virtex-6 devices. For more complete device performance numbers, see [Table 4 - Table 7](#).
3. Based on 18K block RAMs (or 36K - select appropriate size).
4. Performance numbers listed are for Virtex-6 FPGAs. For more complete performance data, see [Performance and Resource Usage, page 10](#).

## Functional Description

There are two basic architectures to implement complex multiplication, given two operands:  $a = a_r + ja_i$  and  $b = b_r + jb_i$ , yielding an output  $p = ab = p_r + jp_i$ .

Direct implementation requires four real multiplications:

$$p_r = a_r b_r - a_i b_i \quad \text{Equation 1}$$

$$p_i = a_r b_i + a_i b_r \quad \text{Equation 2}$$

By exploiting that

$$p_r = a_r b_r - a_i b_i = a_r(b_r + b_i) - (a_r + a_i)b_i \quad \text{Equation 3}$$

$$p_i = a_r b_i + a_i b_r = a_r(b_r + b_i) + (a_i - a_r)b_r \quad \text{Equation 4}$$

a three real multiplier solution can be devised, which trades off one multiplier for three pre-combining adders and increased multiplier wordlength.

## Pinout

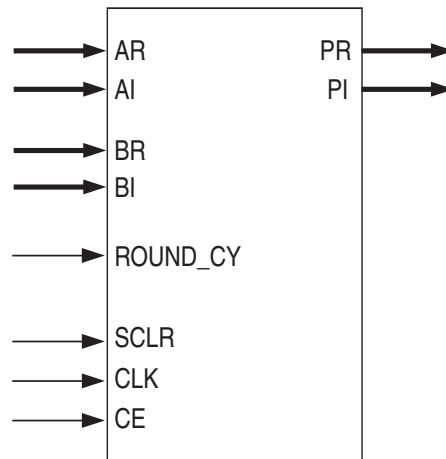

Figure 1: Core Schematic Symbol

This section describes the Complex Multiplier core signals as shown in Figure 1 and described in Table 1. All control inputs are active high. Should an active low input be required for a specific control pin, an inverter must be placed in the path to the pin and is absorbed appropriately during synthesis and/or mapping.

Table 1: Core Signal Pinout

Name	Direction	Description
AR[N-1:0]	Input	Real component of operand <i>A</i> , <i>N</i> bits wide
AI[N-1:0]	Input	Imaginary component of operand <i>A</i> , <i>N</i> bits wide
BR[M-1:0]	Input	Real component of operand <i>B</i> , <i>M</i> bits wide
BI[M-1:0]	Input	Imaginary component of operand <i>B</i> , <i>M</i> bits wide
CLK	Input	Rising-edge clock
CE	Input	Active high Clock Enable
SCLR	Input	Active high Synchronous Clear (SCLR/CE priority is configurable)
ROUND_CY	Input	Carry input to facilitate unbiased rounding
PR[X:Y]	Output	Real component of product <i>P</i>
PI[X:Y]	Output	Imaginary component of product <i>P</i>

## CORE Generator Graphical User Interface

The Complex Multiplier core GUI has a number of fields to set parameter values for the particular instantiation required. This section provides a description of each GUI field.

- **Component Name:** The name of the core component to be instantiated. The name must begin with a letter and be composed of the following characters: a to z, A to Z, 0 to 9 and “\_”.
- **Input Options:** Select the required operand widths. The widths for each operand apply to both the real and imaginary components of each operand.
- **Construction and Optimization:** These options allow the choice of resources to use, and optimization for speed or lower resource use.
  - **Complex Multiplier Construction:** Allows the choice of using LUTs (slice logic) to construct the complex multiplier, or using embedded multipliers/XtremeDSP slices.
  - **Optimization Options:** Selects between Resource and Performance optimization.
    - If the complex multiplier is to be constructed from LUTs (Use LUTs), the only optimization option is Resources.
    - If constructed from embedded multipliers/XtremeDSP slices (Use Mults), Resource or Performance optimization can be selected. In general, Resource optimization uses the 3 real multiplier structure. The core uses the 4 real multiplier structure when the 3 real multiplier structure uses more multiplier resources. Performance optimization always uses the 4 real multiplier structure to allow the best clock frequency performance to be achieved.
- **Output Product Range:** Select the required MSB and LSB of the output product. The values are automatically initialized to provide the full-precision product when the *A* and *B* operand widths are set. The output is sign-extended if required. If rounding is required, set the Output LSB to a value greater than zero to enable the rounding options.
- **Rounding:** If the full-precision product is selected, no rounding options are available. When the Output LSB is greater than zero, either Truncation or Random Rounding can be selected. When Random Rounding is selected, the ROUND\_CY pin is enabled by the GUI so that it is present on the core. See the [Rounding](#) section for further details.
- **Core Latency:** Select the desired latency for the core. The GUI automatically selects the fully-pipelined latency for the specified configuration, and the user may adjust this as required. The label to the right of the drop-down list indicates the optimum latency for maximum performance. If the latency is set to be larger than this optimum value, SRL16-based shift registers at the core output implement the additional delay.

- **Control Signals:** Selects which control signals should be present on the core, and their relative priority. These options are disabled when the core has a latency of zero.
  - **Clock Enable:** Enables the clock enable (CE) pin on the core. All registers in the core are enabled by this signal.
  - **Synchronous Clear:** Enables the synchronous clear (SCLR) pin on the core. All registers in the core are reset by this signal. This can increase resource use and degrade performance, as the number of SRL-based shift registers that can be used is reduced.
  - **SCLR/CE Priority:** When both SCLR and CE pins are present, the priority of SCLR and CE can be selected. The fewest resources are used, and best performance is achieved, when SCLR overrides CE.
- **Resource Estimation Tab:** Clicking on the tab below the GUI symbol displays an estimate of the embedded multiplier/XtremeDSP slice resources used for a particular complex multiplier configuration. This value updates instantaneously with changes in the GUI, allowing trade-offs in implementation to be evaluated immediately.

## Using the Complex Multiplier IP Core

The CORE Generator GUI performs error-checking on all input parameters. Resource estimation and latency information are also available.

Several files are produced when a core is generated, and customized instantiation templates for Verilog and VHDL design flows are provided in the .veo and .vho files, respectively. For detailed instructions, see the CORE Generator software documentation.

## Simulation Models

The core has a number of options for simulation models:

- VHDL behavioral model in the xilinxcorelib library
- VHDL UniSim structural model
- Verilog UniSim structural model

The models required may be selected in the CORE Generator project options.

Xilinx recommends that simulations utilizing UniSim-based structural models are run using a resolution of 1 ps. Some Xilinx library components require a 1 ps resolution to work properly in either functional or timing simulation. The UniSim-based structural models might produce incorrect results if simulation with a resolution other than 1 ps. See the “Register Transfer Level (RTL) Simulation Using Xilinx Libraries” section in *Synthesis and Simulation Design Guide* for more information. This document is part of the ISE® Software Manuals set available at [www.xilinx.com/support/documentation/dt\\_ise.htm](http://www.xilinx.com/support/documentation/dt_ise.htm).

## XCO Parameters

Table 2 defines valid entries for the XCO parameters. Parameters are not case sensitive. Default values are displayed in bold.

Xilinx strongly suggests that XCO parameters are not manually edited in the XCO file; instead, use the CORE Generator GUI to configure the core and perform range and parameter value checking.

Table 2: XCO Parameters

XCO Parameter	Valid Values
component_name	ASCII text using characters: a to z, A to Z, 0 to 9 and ' _ ' ; starting with a letter
APortWidth	8 - 63 (default value is <b>16</b> )
BPortWidth	8 - 63 (default value is <b>16</b> )
OutputWidthHigh	APortWidth+BPortWidth (default value is <b>32</b> )
OutputWidthLow	0 - APortWidth+BPortWidth (default value is <b>0</b> )
MultType	Use_LUTs, <b>Use_Mults</b>
OptimizeGoal	<b>Resources</b> , Performance
RoundMode	<b>Truncate</b> , Random_Rounding
Latency	0 to 50 (default value depends on configuration)
ClockEnable	<b>false</b> , true
SyncClear	<b>false</b> , true
SclrCePriority	<b>SCLR_overrides_CE</b> , CE_overrides_SCLR

## Migrating to Complex Multiplier v3.1 from Earlier Versions

### XCO Parameter Changes

The CORE Generator core update functionality may be used to update an existing XCO file from previous Complex Multiplier versions to Complex Multiplier v3.1. The XCO parameters in Complex Multiplier v3.1 are different from the parameters in versions 2.0 and 2.1 of the core.

For more information on this feature, see the CORE Generator software documentation.

### Port Changes

There are no differences in port naming conventions, polarities, priorities or widths between versions. Clock enable is an optional pin in versions 3.0 and 3.1, and clock enable/synchronous clear priority is also configurable.

### Latency changes

The latency of Complex Multiplier v3.1 might be different compared to the previous implementation, and the update process cannot account for this. The CORE Generator GUI for both versions should be consulted and the latency value compared. If the latencies are different, the latency may be manually configured in the Complex Multiplier v3.1 GUI to match the previous configuration.

## System Generator for DSP Graphical User Interface

This section describes each tab of the System Generator for DSP GUI and details the parameters that differ from the CORE Generator GUI.

The Complex Multiplier core may be found in the Xilinx Blockset in the Math section. The block is called “Complex Multiplier 3.1.”

See the System Generator for DSP Help page for the “Complex Multiplier 3.1” block for more information on parameters not mentioned here.

### Page 1

Page 1 is used to specify the complex multiplier construction, optimization options and output width in a similar way to the CORE Generator GUI. Setting “Output LSB” to a value greater than zero enables the rounding options on Page 2.

### Page 2

Page 2 is used to specify latency, output product rounding options and block control signals.

- **Core Latency:** Selecting the “-1” latency option fully-pipelines the core for the specified configuration, yielding maximum performance. Alternatively, the required latency may be explicitly specified, as in the CORE Generator GUI, with the values 0 to 50.
- **Output Rounding:** Selecting the “Random Rounding” option adds a ROUND\_CY pin to the block to allow a carry-in bit to be input.
- **en:** Checking this box specifies if the core is to have a clock enable pin (the equivalent of selecting the CE option in the CORE Generator GUI).
- **rst:** Checking this box specifies if the core is to have a synchronous reset pin (the equivalent of selecting the SCLR option in the CORE Generator GUI).

### Implementation

This page is used only for System Generator for DSP FPGA area estimation, and has no equivalent parameters on the CORE Generator GUI.

## Control Signals

### Clock Enable

If the CE pin is present on the core, driving the pin low pauses the core in its current state. All logic within the core is paused. Driving the CE pin high allows the core to continue processing.

If CE and SCLR priority is set such that SCLR overrides CE, asserting SCLR while CE is held low still resets the core.

### Synchronous Clear

If the SCLR pin is present on the core, driving the pin high results in all registers being reset to their initial values.

If CE and SCLR priority is set such that CE overrides SCLR, SCLR resets the core only when CE is asserted.

## Rounding

In a DSP system, especially if the system contains feedback, the wordlength growth through the multiplier should be offset by quantizing the results. Quantization, or reduction in wordlength, results in error, introduces quantization noise, and can introduce bias. For best results it is favorable to select a quantization method that introduces zero mean noise and minimizes noise variance. Figure 2 illustrates the quantization method used for truncation.

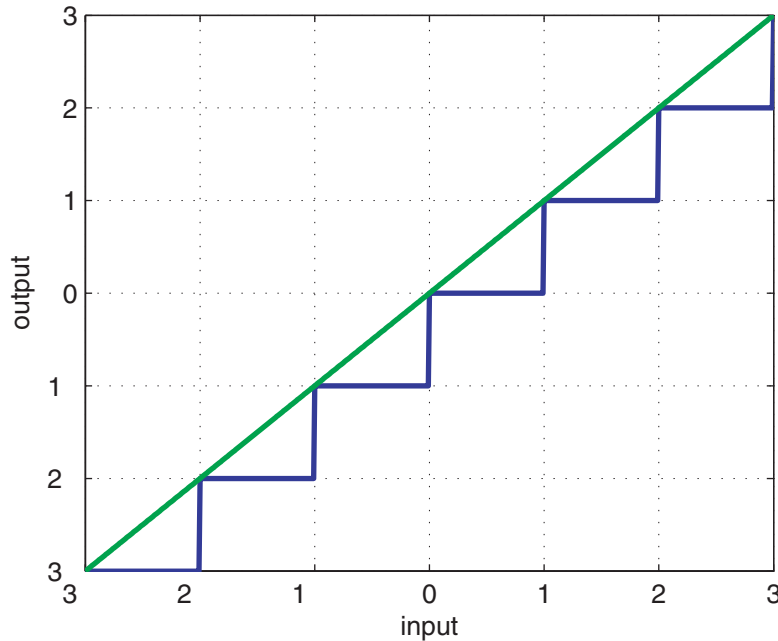

Figure 2: Truncation

For truncation the probability density function (PDF) of the noise is:

$$p(e) = \begin{cases} \frac{1}{\Delta} & -\Delta < e < 0 \\ 0 & \text{otherwise} \end{cases} \quad \text{Equation 5}$$

therefore the mean and the variance of the error introduced are:

$$m_e = \int_{-\Delta}^0 ep(e)de = \frac{1}{\Delta} \int_{-\Delta}^0 ede = -\frac{\Delta}{2} \quad \text{Equation 6}$$

$$\sigma_e^2 = \int_0^{\Delta} e^2 p(e)de = \frac{1}{\Delta} \int_0^{\Delta} e^2 de = \frac{\Delta^2}{3} \quad \text{Equation 7}$$

Implementing truncation has no cost in hardware; the fractional bits are simply trimmed.

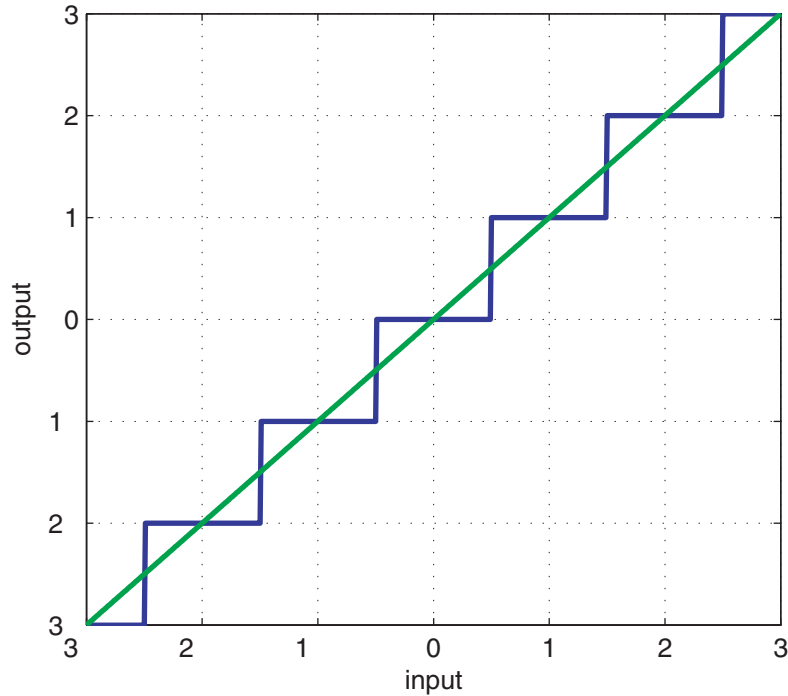

Figure 3: Rounding

For rounding the (PDF) of the noise is:

$$p(e) = \begin{cases} \frac{1}{\Delta} & -\Delta/2 < e < \Delta/2 \\ 0 & \text{otherwise} \end{cases} \quad \text{Equation 8}$$

the mean and the variance of the error introduced are:

$$m_e = \int_{-\Delta/2}^{\Delta/2} ep(e)de = \frac{1}{\Delta} \int_{-\Delta/2}^{\Delta/2} ede = 0 \quad \text{Equation 9}$$

$$\sigma_e^2 = \int_{-\Delta/2}^{\Delta/2} e^2 p(e)de = \frac{1}{\Delta} \int_{-\Delta/2}^{\Delta/2} e^2 de = \frac{\Delta^2}{12} \quad \text{Equation 10}$$

Therefore, the ideal rounder introduces no DC bias to the signal flow. If the full product word (for example,  $a_r b_r - a_i b_i$ ) is represented with  $B_p$  bits, and the actual result of the core (for example,  $p_r$ ) is represented with  $B_R$  bits, then bits  $B_p-1 \dots B_p-B_R$  are the integer part, and  $B_p-B_R-1 \dots 0$  are the fractional part of the result.



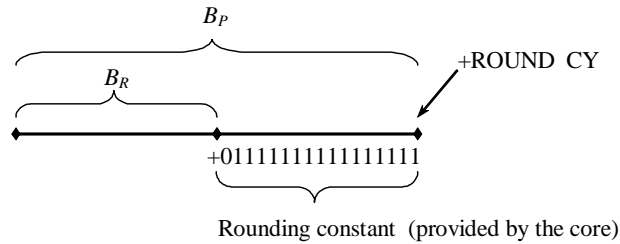

Figure 4: Rounding to  $B_R$  Bits from  $B_P$  Bits

To implement the rounding function shown in Figure 3, 0.5 (represented in  $B_P B_P - B_R$  format) has to be added to the full product word, then the lower  $B_P - B_R$  bits need to be truncated. However, if the fractional part is exactly 0.5, this method always rounds up, which introduces positive bias to the computation. Also, if the rounding constant is -1 (Figure 4), 0.5 would be always rounded down, introducing negative bias.

If 0.5 is rounded using a static rule, the resulting quantization always introduces bias. To avoid bias, rounding has to be randomized. Therefore, the core adds a rounding constant, and an extra 1 should be added with  $\frac{1}{2}$  probability, thus dithering the exact rounding threshold. Typical round carry sources being used extensively as control signals are listed in Table 3.

Table 3: Unbiased Rounding Sources

0.5 Rounding Rule	Round Carry Source
Round towards 0	-MSB(P)
Round towards +/- infinity	MSB(P)
Round towards nearest even	LSB(P)

Rounding of the results is not trivial when multiple, cascaded XtremeDSP slices are involved in the process, such as evaluation of Equation 9 or Equation 10. The sign of the output ( $MSB_o$ ) cannot be predicted from the operands before the actual multiplications and additions take place, and would incur additional latency or resource to implement outside the XtremeDSP slices. Therefore an external signal should be used to feed the round carry input, through the *ROUND\_CY* pin.

A good candidate for a source can be a clock-dividing flip-flop, or any 50% duty cycle random signal, which is not correlated with the fractional part of the results. For predictable behavior (as for bit-true modeling) the *ROUND\_CY* signal might need to be connected to a CLK independent source in the user design, such as an LSB of one of the complex multiplier inputs.

Nevertheless, even when a static rule is used (such as tying *ROUND\_CY* = '0'), bias and quantization error are reduced compared to using truncation.

In many cases, for XtremeDSP slice implementation, the addition of the rounding constant is 'free,' as the C port and carry-in input may be utilized. In devices without XtremeDSP slices, the addition of rounding typically requires an extra slice-based adder and an additional cycle of latency.

## Hardware Implementation

### Three Real Multiplier Solution

The three real multiplier implementation maps well to devices that have a pre-adder as part of the XtremeDSP slice (such as Spartan-6 and Virtex-6 FPGAs), saving slice resources.

In general, the three multiplier solution uses more slice resources (LUTs/flip-flops) and have a lower maximum achievable clock frequency than the four multiplier solution.

### Four Real Multiplier Solution

The four real multiplier solution makes maximum use of embedded multiplier/XtremeDSP slice resources, and has higher clock frequency performance than the three real multiplier solution, in many cases reaching the maximum clock frequency of the FPGA device.

It still consumes slice resources for pipeline balancing, but this slice cost is always less than that required by the equivalent three real multiplier solution.

### LUT-based Solution

The core offers the option to build the complex multiplier using LUTs only. While this option uses a significant number of slices, achieves a lower maximum clock frequency and uses more power than embedded multiplier/XtremeDSP slice implementations, it might be suitable for applications where embedded multipliers/XtremeDSP slices are in limited supply (such as Virtex-5 LX FPGAs), or where lower clock rates are in use.

The three real multiplier configuration is used exclusively when LUT implementation is selected.

## Performance and Resource Usage

[Table 4](#) through [Table 7](#) provide performance and resource usage information for a number of different core configurations.

The maximum clock frequency results were obtained by double-registering input and output ports to reduce dependence on I/O placement. The inner level of registers used a separate clock signal to measure the path from the input registers to the first output register through the core.

The resource usage results do not include the preceding “characterization” registers and represent the true logic used by the core to implement a single Complex Multiplier. LUT counts include SRL16s or SRL32s (according to device family) and LUTs used as route-throughs.

The map options used were: `"map -pr b -ol high"`

The par options used were: `"par -ol high"`

Clock frequency does not take clock jitter into account and should be derated by an amount appropriate to the clock source jitter specification.

The Virtex-6 FPGA test cases in [Table 4](#) used an XC6VLX75T-FF784 (-1 speed grade) device and ISE speed file version "ADVANCED 1.01 2009-08-31."

**Table 4: Virtex-6 Performance and Resource Usage**

<b>Complex Multiplier Configuration</b>	<b>Core Latency (Cycles)</b>	<b>Maximum Clock Frequency (MHz)</b>	<b>LUT/FF Pairs</b>	<b>LUT6s</b>	<b>FFs</b>	<b>XtremeDSP Slices</b>
16x16 Use Mults Resources	6	450	32	32	64	3
16x16 Use Mults Performance	4	450	0	0	0	4
16x16 Use LUTs Resources	6	431	1074	1062	1080	0
32x16 Use Mults Resources	9	450	171	134	263	6
32x16 Use Mults Performance	6	450	42	40	80	8
32x16 Use LUTs Resources	7	366	2046	2038	2087	0
32x32 Use Mults Resources	13	438	348	329	460	12
32x32 Use Mults Performance	10	450	150	145	286	16
32x32 Use LUTs Resources	7	310	3769	3769	3679	0

The Virtex-5 FPGA test cases in [Table 5](#) used an XC5VLX50T-FF676 (-1 speed grade) device and ISE speed file version "PRODUCTION 1.66 2009-08-31, STEPPING level 0."

**Table 5: Virtex-5 Performance and Resource Usage**

<b>Complex Multiplier Configuration</b>	<b>Core Latency (Cycles)</b>	<b>Maximum Clock Frequency (MHz)</b>	<b>LUT/FF Pairs</b>	<b>LUT6s</b>	<b>FFs</b>	<b>XtremeDSP Slices</b>
16x16 Use Mults Resources	6	450	117	117	83	3
16x16 Use Mults Performance	4	450	0	0	0	4
16x16 Use LUTs Resources	6	365	1100	1035	1080	0
32x16 Use Mults Resources	9	450	283	208	249	6
32x16 Use Mults Performance	6	450	110	50	110	8
32x16 Use LUTs Resources	7	310	2134	1962	2063	0
32x32 Use Mults Resources	13	403	526	468	460	12
32x32 Use Mults Performance	10	450	286	241	286	16
32x32 Use LUTs Resources	7	276	3809	3721	3697	0

The Spartan-6 FPGA test cases in [Table 6](#) used an XC6SLX45T-FGG484 (-2 speed grade) device and ISE speed file version "ADVANCED 1.01 2009-08-31."

**Table 6: Spartan-6 Performance and Resource Usage**

<b>Complex Multiplier Configuration</b>	<b>Core Latency (Cycles)</b>	<b>Maximum Clock Frequency (MHz)</b>	<b>LUT/FF Pairs</b>	<b>LUT6s</b>	<b>FFs</b>	<b>XtremeDSP Slices</b>
16x16 Use Mults Resources	6	250	32	32	64	3
16x16 Use Mults Performance	4	250	0	0	0	4
16x16 Use LUTs Resources	6	180	1057	1057	1053	0
32x16 Use Mults Resources	11	212	166	144	247	6
32x16 Use Mults Performance	7	250	58	56	110	8
32x16 Use LUTs Resources	7	165	1984	1984	1997	0
32x32 Use Mults Resources	17	196	348	342	460	12
32x32 Use Mults Performance	12	244	168	162	318	16
32x32 Use LUTs Resources	7	125	3713	3713	3697	0

The Spartan-3A DSP FPGA test cases in [Table 7](#) used an XC3SD3400A-FG676 (-4 speed grade) device and ISE speed file version "PRODUCTION 1.33 2009-08-31."

**Table 7: Spartan-3A DSP Performance and Resource Usage**

<b>Complex Multiplier Configuration</b>	<b>Core Latency (Cycles)</b>	<b>Maximum Clock Frequency (MHz)</b>	<b>Slices</b>	<b>LUT4s</b>	<b>FFs</b>	<b>XtremeDSP Slices</b>
16x16 Use Mults Resources	6	250	32	64	64	3
16x16 Use Mults Performance	4	250	0	0	0	4
16x16 Use LUTs Resources	6	172	574	1053	1053	0
32x16 Use Mults Resources	11	188	182	207	247	6
32x16 Use Mults Performance	7	250	74	80	110	8
32x16 Use LUTs Resources	7	141	1129	1988	2023	0
32x32 Use Mults Resources	17	180	325	518	460	12
32x32 Use Mults Performance	12	250	201	224	318	16
32x32 Use LUTs Resources	7	125	1953	3721	3697	0

## Support

Xilinx provides technical support for this LogiCORE product when used as described in the product documentation. Xilinx cannot guarantee timing, functionality, or support of product if implemented in devices that are not defined in the documentation, if customized beyond that allowed in the product documentation, or if changes are made to any section of the design labeled *DO NOT MODIFY*.

See the *IP Release Notes Guide* [XTP025](#) for further information on this core. On the first page there is a link to “All DSP IP.” The relevant core can then be selected from the displayed list.

For each core, there is a master Answer Record that contains the Release Notes and Known Issues list for the core being used. The following information is listed for each version of the core:

- New Features
- Bug Fixes
- Known Issues

## Ordering Information

This LogiCORE IP module is included at no additional cost with the Xilinx ISE Design Suite software and is provided under the terms of the [Xilinx End User License Agreement](#). Use the CORE Generator software included with the ISE Design Suite to generate the core. For more information, please visit the [core page](#).

Information about additional Xilinx LogiCORE modules is available at the [Xilinx IP Center](#). For pricing and availability of other Xilinx LogiCORE modules and software, please contact your local Xilinx [sales representative](#).

## Revision History

Date	Version	Description of Revisions
5/21/04	1.0	Initial Xilinx release of the core.
11/11/04	2.0	Document updated to support Complex Multiplier core v2.0 and Xilinx software v6.3i.
4/28/05	2.1	Document updated to support Complex Multiplier core v2.1 and Xilinx software v7.1i.
12/22/08	3.0-draft-C	Flowed into current DS000-IP template, v3.1
4/29/09	3.0	Document updated to support Complex Multiplier core v3.0 and Xilinx software 11.1.
12/02/09	3.1	Document updated to support Complex Multiplier core v3.1 and Xilinx software 11.4.
03/01/11	4.0	Support added for Virtex-7 and Kintex-7. ISE Design Suite 13.1

## Notice of Disclaimer

Xilinx is providing this product documentation, hereinafter “Information,” to you “AS IS” with no warranty of any kind, express or implied. Xilinx makes no representation that the Information, or any particular implementation thereof, is free from any claims of infringement. You are responsible for obtaining any rights you may require for any implementation based on the Information. All specifications are subject to change without notice. XILINX EXPRESSLY DISCLAIMS ANY WARRANTY WHATSOEVER WITH RESPECT TO THE ADEQUACY OF THE INFORMATION OR ANY IMPLEMENTATION BASED THEREON, INCLUDING BUT NOT LIMITED TO ANY WARRANTIES OR REPRESENTATIONS THAT THIS IMPLEMENTATION IS FREE FROM CLAIMS OF INFRINGEMENT AND ANY IMPLIED WARRANTIES OF MERCHANTABILITY OR FITNESS FOR A PARTICULAR PURPOSE. Except as stated herein, none of the Information may be copied, reproduced, distributed, republished, downloaded, displayed, posted, or transmitted in any form or by any means including, but not limited to, electronic, mechanical, photocopying, recording, or otherwise, without the prior written consent of Xilinx.