

I/O Module v3.1

LogiCORE IP Product Guide

Vivado Design Suite

PG111 December 20, 2017

Table of Contents

IP Facts

Chapter 1: Overview

Feature Summary	6
Licensing and Ordering	8

Chapter 2: Product Specification

Standards	9
Performance	9
Resource Utilization	10
Port Descriptions	10
Register Space	12

Chapter 3: Designing with the Core

General Design Guidelines	23
LMB Timing	28
Clocking	28
Resets	29
Protocol Description	29

Chapter 4: Design Flow Steps

Customizing and Generating the Core	30
Constraining the Core	43
Simulation	44
Synthesis and Implementation	44

Appendix A: Upgrading

Upgrade	45
---------------	----

Appendix B: Debugging

Finding Help on Xilinx.com	46
Debug Tools	47
Simulation Debug	48

Hardware Debug	48
Appendix C: Application Software Development	
Device Drivers	50
Appendix D: Additional Resources and Legal Notices	
Xilinx Resources	51
References	51
Revision History	52
Please Read: Important Legal Notices	52

Introduction

The LogiCORE™ IP I/O Module core is a highly integrated and light-weight implementation of a standard set of peripherals.

The I/O Module core is a standalone version of the tightly coupled I/O module included in the LogiCORE IP MicroBlaze™ Micro Controller System (MCS) core. Using the I/O Module core, a system equivalent to MicroBlaze MCS can be design using the Vivado® Design Suite.

The I/O Module core connects to MicroBlaze through the lmb_v10 bus.

Features

- LMB v1.0 bus interfaces to communicate with MicroBlaze
- I/O bus
- Interrupt controller with fast interrupt mode support
- UART
- Fixed Interval Timers
- Programmable Interval Timers
- General purpose inputs
- General purpose outputs
- Support for Triple Modular Redundancy (TMR)

LogiCORE IP Facts Table	
Core Specifics	
Supported Device Family ⁽¹⁾	UltraScale+™ UltraScale™ Zynq®-7000 All Programmable SoC 7 Series
Supported User Interfaces	Local Memory Bus (LMB), Dynamic Reconfiguration Port (DRP)
Resources	Performance and Resource Utilization web page
Provided with Core	
Design Files	Vivado: RTL
Example Design	Not Provided
Test Bench	Not Provided
Constraints File	Not Provided
Simulation Model	VHDL Behavioral
Supported S/W Driver ⁽²⁾	Standalone
Tested Design Flows⁽³⁾	
Design Entry	Vivado Design Suite
Simulation	For supported simulators, see the Xilinx Design Tools: Release Notes Guide .
Synthesis	Vivado Synthesis
Support	
Provided by Xilinx at the Xilinx Support web page	

Notes:

1. For a complete listing of supported devices, see the Vivado IP Catalog.
2. Standalone driver details can be found in the SDK directory (<install_directory>/doc/usenglish/xilinx_drivers.htm). Linux OS and driver support information is available from the [Xilinx Wiki page](#).
3. For the supported versions of the tools, see the [Xilinx Design Tools: Release Notes Guide](#).

Overview

The I/O Module core is a light-weight implementation of a set of standard I/O functions commonly used in a MicroBlaze™ processor sub-system. The input/output signals of the I/O Module core are shown in Figure 1-1. The detailed list of signals are listed and described in Table 2-1. See the description of LMB Signals in the MicroBlaze Bus Interfaces chapter in the *MicroBlaze Processor Reference Guide* (UG984) [Ref 1].

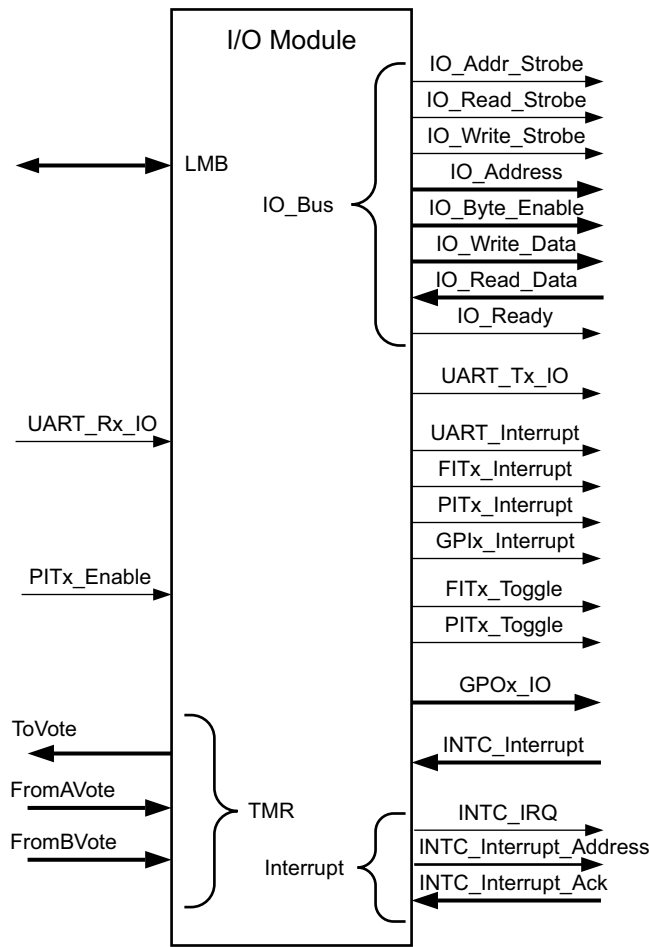

X18699-012717

Figure 1-1: I/O Module Block Diagram

In a MicroBlaze system the I/O Module core is typically connected according to [Figure 1-2](#).

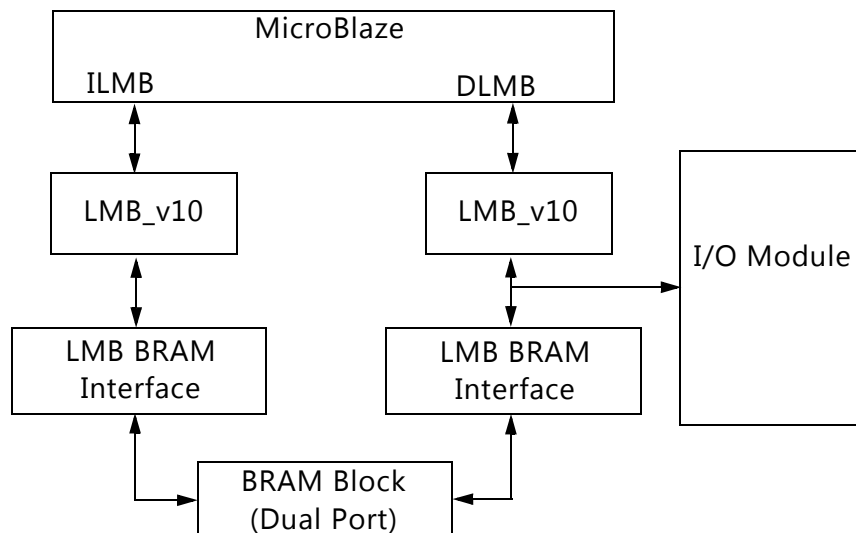

Figure 1-2: Typical MicroBlaze System

Feature Summary

I/O Bus

The I/O bus provides a simple bus for accessing to external modules. The I/O bus is mapped in the MicroBlaze memory space, with the I/O bus address directly reflecting the byte address used by MicroBlaze load/store instructions. I/O bus data is 32-bit wide, with byte enables to write byte and half-word data.

The I/O bus is fully compatible with the Xilinx Dynamic Reconfiguration Port (DRP).

UART

The Universal Asynchronous Receiver Transmitter (UART) interface provides the controller interface for asynchronous serial data transfers. Features supported include:

- One transmit and one receive channel (full duplex)
- Configurable number of data bits in a character (5-8)
- Configurable parity bit (odd or even)
- Configurable and programmable baud rate

Fixed Interval Timer

The Fixed Interval Timer (FIT) generates a strobe signal at fixed intervals. The Fixed Interval Timer asserts the output signal and generates an interrupt according to the selected parameter values.

Programmable Interval Timer

The Programmable Interval Timer (PIT) has a configurable width from 1 to 32. The PIT operation and period are controlled by software. An interrupt can be generated when the timer expires.

General Purpose Output

The General Purpose Output (GPO) drives I/O Module GPO output signals defined by the value of the corresponding GPO register, programmable from software. The width and initial value are defined by parameters.

General Purpose Input

The General Purpose Input (GPI) makes it possible for software to sample the value of the I/O Module GPI input signals by reading the GPI register. The width and whether to generate an interrupt are defined by parameters.

Interrupt Controller

The Interrupt Controller (INTC) handles both I/O module internal interrupt events and external ones. The internal interrupt events originate from the UART, the Fixed Interval Timers, the Programmable Interval Timers, or the General Purpose Inputs.

Triple Modular Redundancy

When enabling Triple Modular Redundancy (TMR), the I/O Module performs majority voting on all internal registers. The voting is performed between the internal value, and the register values from the two other I/O Module cores in a triplicated sub-system, by using the voting signals interconnecting the cores.

This functionality is intended to be used together with the TMR IP cores, which provide a complete TMR solution. See *Triple Modular Redundancy (TMR)* (PG268) [Ref 3] for details.

Licensing and Ordering

This Xilinx® LogiCORE™ IP module is provided at no additional cost with the Xilinx Vivado® Design Suite under the terms of the [Xilinx End User License](#). Information about this and other Xilinx LogiCORE IP modules is available at the [Xilinx Intellectual Property](#) page. For information about pricing and availability of other Xilinx LogiCORE IP modules and tools, contact your [local Xilinx sales representative](#).

Product Specification

Standards

The I/O bus interface provided by the I/O Module core is fully compatible with the Xilinx Dynamic Reconfiguration Port (DRP). For a detailed description of the DRP, see the *7 Series FPGAs Configuration User Guide (UG740)* [Ref 2].

Performance

The frequency and latency of the I/O Module core are optimized for use together with MicroBlaze™. This means that the frequency targets are aligned to MicroBlaze targets as well as the access latency optimized for MicroBlaze data access.

Maximum Frequencies

For details about performance, visit [Performance and Resource Utilization](#).

Latency

- Data read from I/O Module core registers is available two clock cycles after the address strobe is asserted.
- Data write to I/O Module core registers is performed the clock cycle after the address strobe is asserted.
- Data accesses to peripherals connected on the I/O bus take three clock cycles plus the number of wait states introduced by the accessed peripheral.

Throughput

The maximum throughput when using the I/O bus is one read or write access every three clock cycles.

Resource Utilization

For details about resource utilization, visit [Performance and Resource Utilization](#).

Port Descriptions

The I/O ports and signals for the I/O Module core are listed and described in [Table 2-1](#).

Table 2-1: I/O Module I/O Signals

Port Name	MSB:LSB	I/O	Description
LMB Signals			
LMB_ABus	0:C_LMB_AWIDTH-1	I	LMB Address Bus
LMB_WriteDBus	0:C_LMB_DWIDTH-1	I	LMB Write Data Bus
LMB_ReadStrobe		I	LMB Read Strobe
LMB_AddrStrobe		I	LMB Address Strobe
LMB_WriteStrobe		I	LMB Write Strobe
LMB_BE	0:C_LMB_DWIDTH/8-1	I	LMB Byte Enable Bus
SI_DBus	0:C_LMB_DWIDTH-1	O	LMB Read Data Bus
SI_Ready		O	LMB Data Ready
SI_Wait		O	LMB Wait
SI_CE		O	LMB Correctable Error
SI_UE		O	LMB Uncorrectable Error
I/O Bus Signals			
IO_Addr_Strobe		O	Address strobe signals valid I/O bus output signals
IO_Read_Strobe		O	I/O bus access is a read
IO_Write_Strobe		O	I/O bus access is a write
IO_Address	31:0	O	Address for access
IO_Byte_Enable	3:0	O	Byte enables for access
IO_Write_Data	31:0	O	Data to write for I/O bus write access
IO_Read_Data	31:0	I	Read data for I/O bus read access
IO_Ready		I	Ready handshake to end I/O bus access
UART Signals			
UART_Rx_IO		I	Receive Data
UART_Tx_IO		O	Transmit Data

Table 2-1: I/O Module I/O Signals (Cont'd)

Port Name	MSB:LSB	I/O	Description
UART_Interrupt		O	UART Interrupt
FIT Signals			
FITx_Interrupt ⁽¹⁾		O	FITx timer expired
FITx_Toggle ⁽¹⁾		O	Inverted FITx_Toggle when FITx timer expires
PIT Signals			
PITx_Enable ⁽¹⁾		I	PITx count enable when C_PITx_PRESCALER = External
PITx_Interrupt ⁽¹⁾		O	PITx timer expired
PITx_Toggle ⁽¹⁾		O	Inverted PITx_Toggle when PITx expires
GPO Signals			
GPOx ⁽¹⁾	[C_GPOx_SIZE - 1]:0	O	GPOx Output
GPI Signals			
GPIx ⁽¹⁾	[C_GPIx_SIZE - 1]:0	I	GPIx Input
GPIx_Interrupt ⁽¹⁾	[C_GPIx_SIZE - 1]:0	O	GPIx input changed in the specified way
INTC Signals			
INTC_Interrupt ⁽²⁾	0:[C_INTC_INTR_SIZE - 1]	I	External interrupt inputs
INTC_IRQ		O	Interrupt Output
INTC_Interrupt_Address	[C_INTC_ADDR_WIDTH-1]:0	O	Interrupt Address Output
INTC_Interrupt_Ack	1:0	I	Interrupt Acknowledge Input
INTC_IRQ_OUT		O	Interrupt Output for external connection, enabled with parameter C_INTC_USE_IRQ_OUT
TMR Signals			
TMR_Rst		I	TMR Reset
TMR_Disable		I	TMR Disable
ToVote	1023:0	O	TMR Voting Output
FromAVote	1023:0	I	TMR Voting Input A
FromBVote	1023:0	I	TMR Voting Input B

Notes:

- x = 1, 2, 3 or 4
- Each of the interrupt inputs is treated as synchronous to the clock unless the corresponding bit in the parameter C_INTC_ASYNC_INTR is set. In that case, the input is synchronized with the number of flip-flops defined by the parameter C_INTC_NUM_SYNC_FF.

Parameter - Port Dependencies

The width of many of the I/O Module core signals depends on design parameters. The dependencies between the design parameters and I/O signals are shown in [Table 2-2](#).

Table 2-2: Parameter-Port Dependencies

Parameter Name	Ports (Port width depends on parameter)
C_LMB_AWIDTH	LMB_ABus
C_INTC_INTR_SIZE	INTC_Interrupt
C_INTC_ADDR_WIDTH	INTC_Interrupt_Address
C_GPO1_SIZE	GPO1
C_GPO2_SIZE	GPO2
C_GPO3_SIZE	GPO3
C_GPO4_SIZE	GPO4
C_GPI1_SIZE	GPI1
C_GPI2_SIZE	GPI2
C_GPI3_SIZE	GPI3
C_GPI4_SIZE	GPI4

When MicroBlaze is configured to use an extended data address from 32 to 64 bits, the I/O Module core uses the extended address to determine if the core is accessed.

Register Space

The register addresses for the core are described in [Table 2-3](#).

Table 2-3: I/O Module Register Address Map

Base Address + Offset (hex)	Register	Access Type	Description
C_BASEADDR + 0x0	UART_RX	R	UART Receive Data Register
C_BASEADDR + 0x4	UART_TX	W	UART Transmit Data Register
C_BASEADDR + 0x8	UART_STATUS	R	UART Status Register
C_BASEADDR + 0xC	IRQ_MODE	W	Interrupt Mode Register
C_BASEADDR + 0x10	GPO1	W	General Purpose Output 1 Register
C_BASEADDR + 0x14	GPO2	W	General Purpose Output 2 Register
C_BASEADDR + 0x18	GPO3	W	General Purpose Output 3 Register
C_BASEADDR + 0x1C	GPO4	W	General Purpose Output 4 Register
C_BASEADDR + 0x20	GPI1	R	General Purpose Input 1 Register
C_BASEADDR + 0x24	GPI2	R	General Purpose Input 2 Register

Table 2-3: I/O Module Register Address Map (Cont'd)

Base Address + Offset (hex)	Register	Access Type	Description
C_BASEADDR + 0x28	GPI3	R	General Purpose Input 3 Register
C_BASEADDR + 0x2C	GPI4	R	General Purpose Input 4 Register
C_BASEADDR + 0x30	IRQ_STATUS	R	Interrupt Status Register
C_BASEADDR + 0x34	IRQ_PENDING	R	Pending Interrupt Register
C_BASEADDR + 0x38	IRQ_ENABLE	W	Interrupt Enable Register
C_BASEADDR + 0x3C	IRQ_ACK	W	Interrupt Acknowledge Register
C_BASEADDR + 0x40	PIT1_PRELOAD	W	PIT1 Preload Register
C_BASEADDR + 0x44	PIT1_COUNTER	R	PIT1 Counter Register
C_BASEADDR + 0x48	PIT1_CONTROL	W	PIT1 Control Register
C_BASEADDR + 0x4C	UART_BAUD	W	UART Programmable Baud Rate
C_BASEADDR + 0x50	PIT2_PRELOAD	W	PIT2 Preload Register
C_BASEADDR + 0x54	PIT2_COUNTER	R	PIT2 Counter Register
C_BASEADDR + 0x58	PIT2_CONTROL	W	PIT2 Control Register
C_BASEADDR + 0x5C	Reserved		
C_BASEADDR + 0x60	PIT3_PRELOAD	W	PIT3 Preload Register
C_BASEADDR + 0x64	PIT3_COUNTER	R	PIT3 Counter Register
C_BASEADDR + 0x68	PIT3_CONTROL	W	PIT3 Control Register
C_BASEADDR + 0x6C	Reserved		
C_BASEADDR + 0x70	PIT4_PRELOAD	W	PIT4 Preload Register
C_BASEADDR + 0x74	PIT4_COUNTER	R	PIT4 Counter Register
C_BASEADDR + 0x78	PIT4_CONTROL	W	PIT4 Control Register
C_BASEADDR + 0x7C	Reserved		
C_BASEADDR + 0x80 - C_BASEADDR + 0xFC	IRQ_VECTOR_0 - IRQ_VECTOR_31	W	Interrupt Address Vector Registers
(C_BASEADDR + 0x100) - C_HIGHADDR	Reserved		
C_IO_BASEADDR - C_IO_HIGHADDR	I/O bus	RW	Mapped to I/O bus address output IO_Address

UART Receive Data Register (UART_RX)

This register contains data received by the UART. Reading this location results in reading the current word from the register. When a read request is issued without having received a new character, the previously read data is read again. This register is a read-only register. Issuing a write request to the register does nothing but generate the write acknowledgment. The register is implemented if C_USE_UART_RX is set to 1. Table 2-4 and Table 2-5 describe the UART Receive data register.

Table 2-4: UART Receive Data Register (UART_RX) (C_DATA_BITS=8)

Reserved		UART_RX	
31	8	7	0

Table 2-5: UART Receive Data Register Bit Definitions

Bit(s)	Name	Core Access	Reset Value	Description
31:C_UART_DATA_BITS	-	R	0	Reserved
[C_UART_DATA_BITS-1]:0	UART_RX	R	0	UART Receive Data

UART Transmit Data Register (UART_TX)

A register contains data to be output by the UART. Data to be transmitted is written into this register. This is write only location. Issuing a read request to this register generates the read acknowledgment with zero data. Writing this register when the character has not been transmitted will overwrite previously written data, resulting in loss of data. The register is implemented if C_USE_UART_TX is set to 1. Table 2-6 and Table 2-7 describe the UART Transmit data register.

Table 2-6: UART Transmit Data Register (UART_TX) (C_DATA_BITS=8)

Reserved		UART_TX	
31	8	7	0

Table 2-7: UART Transmit Data Register Bit Definitions

Bit(s)	Name	Core Access	Reset Value	Description
31:C_UART_DATA_BITS	-	R	0	Reserved
[C_UART_DATA_BITS-1]:0	UART_TX	R	0	UART Transmit Data

UART Status Register (UART_Status)

The UART Status register contains the status of the receive and transmit registers, and if there are any errors. This is read only register. If a write request is issued to status register it will do nothing but generate write acknowledgment. The register is implemented if C_USE_UART_RX or C_USE_UART_TX is set to 1. Table 2-8 and Table 2-9 describe the UART Status register.

Table 2-8: UART Status Register (UART_Status)

Reserved		UART_Status	
31	8	7	0

Table 2-9: UART Status Register Bit Definitions

Bit(s)	Name	Core Access	Reset Value	Description
7	Parity Error	R	0	Indicates that a parity error has occurred after the last time the status register was read. If the UART is configured without any parity handling, this bit is always '0'. The received character is written into the receive register. This bit is cleared when the status register is read. 0 = No parity error has occurred 1 = A parity error has occurred
6	Frame Error	R	0	Indicates that a frame error has occurred after the last time the status register was read. Frame Error is defined as detection of a stop bit with the value 0. The receive character is ignored and not written to the receive register. This bit is cleared when the status register is read. 0 = No Frame error has occurred 1 = A frame error has occurred
5	Overrun Error	R	0	Indicates that an overrun error has occurred since the last time the status register was read. Overrun occurs when a new character has been received but the receive register has not been read. The received character is ignored and not written into the receive register. This bit is cleared when the status register is read. 0 = No interrupt has occurred 1 = Interrupt has occurred
4	-	R	0	Reserved
3	Tx Used	R	0	Indicates if the transmit register is in use 0 = Transmit register is not in use 1 = Transmit register is in use
2	-	R	0	Reserved
1	-	R	0	Reserved
0	Rx Valid Data	R	0	Indicates if the receive register has valid data 0 = Receive register is empty 1 = Receive register has valid data

UART Programmable Baud Rate Register (UART_BAUD)

This register sets the baud rate when using programmable baud rate. The initial value of the register is determined from the selected fixed baud rate C_UART_BAUDRATE and the clock frequency C_FREQ, using the formula:

$$\text{UART_BAUD} = \frac{\text{C_FREQ}}{\text{C_UART_BAUDRATE} \cdot 16} - 1$$

Table 2-10 and Table 2-11 describe the UART Programmable Baud Rate register.

Table 2-10: UART Programmable Baud Rate Register (UART_BAUD)

Reserved		UART_BAUD	
31	20	19	0

Table 2-11: UART Programmable Baud Rate Register Bit Definitions

Bit(s)	Name	Core Access	Reset Value	Description
31:20	-	-	-	Reserved
19:0	UART_BAUD	W	See above	Programmed UART Baud Rate

General Purpose Output x Register (GPOx) (x = 1, 2, 3 or 4)

This register holds the value that is driven to the corresponding bits in the I/O Module GPOx port output signals. All bits in the register are updated when the register is written. This register is not implemented if the value of C_USE_GPOx is 0. [Table 2-12](#) and [Table 2-13](#) describe the General Purpose Output x register.

Table 2-12: General Purpose Output x Register (GPOx)

Reserved		GPOx	
31	C_GPOx_SIZE	C_GPOx_SIZE-1	0

Table 2-13: General Purpose Output x Register Bit Definitions

Bit(s)	Name	Core Access	Reset Value	Description
31:C_GPOx_SIZE	-	-	-	Reserved
[C_GPOx_SIZE-1]:0	GPOx	W	0	Register holds data driven to corresponding bits in the GPO port

General Purpose Input x Register (GPIx) (x=1, 2, 3 or 4)

This register reads the value that is input on the corresponding I/O Module GPIx port input signal bits. This register is not implemented if the value of C_USE_GPIx is 0. [Table 2-14](#) and [Table 2-15](#) describe the General Purpose Input x register.

Table 2-14: General Purpose Input x Register (GPIx)

Reserved		GPIx	
31	C_GPIx_SIZE	C_GPIx_SIZE-1	0

Table 2-15: General Purpose Input x Register Bit Definitions

Bit(s)	Name	Core Access	Reset Value	Description
31:C_GPIx_SIZE	-	R	0	Reserved
[C_GPIx_SIZE-1]:0	GPIx	R	0	Register reads value input on the I/O Module GPIx port input signals

Interrupt Status Register (IRQ_STATUS)

The Interrupt Status register holds information on interrupt events that have occurred. The register is read-only and the IRQ_ACK register should be used to clear individual interrupts. Table 2-16 and Table 2-17 describe the Interrupt Status register.

Table 2-16: Interrupt Status Register (IRQ_STATUS)

Reserved		INTC_Interrupt		Reserved	Internal Interrupts	
31	C_INTC_EXT_INTR+16	C_INTC_EXT_INTR+15	16	15	14	0

Table 2-17: Interrupt Status Register Bit Definitions

Bit(s)	Name	Core Access	Reset Value	Description
31:[C_INTC_EXT_INTR + 16]	-	R	0	Reserved
[C_INTC_EXT_INTR+15]:16	INTC_Interrupt	R	0	I/O Module external interrupt input signal INTC_Interrupt [C_INTC_EXT_INTR-1:0] mapped to corresponding bit positions in IRQ_STATUS
15	-	R	0	Reserved
14	GPI4	R	0	GPI4 changed
13	GPI3	R	0	GPI3 changed
12	GPI2	R	0	GPI2 changed
11	GPI1	R	0	GPI1 changed
10	FIT4	R	0	FIT4 strobe
9	FIT3	R	0	FIT3 strobe
8	FIT2	R	0	FIT2 strobe
7	FIT1	R	0	FIT1 strobe
6	PIT4	R	0	PIT4 expired
5	PIT3	R	0	PIT3 expired
4	PIT2	R	0	PIT2 expired
3	PIT1	R	0	PIT1 expired
2	UART_RX	R	0	UART Received Data
1	UART_TX	R	0	UART Transmitted Data
0	UART_ERR	R	0	UART Error

Interrupt Pending Register (IRQ_PENDING)

The Interrupt Pending register holds information on enabled interrupt events that have occurred. IRQ_PENDING is the contents of IRQ_STATUS bit-wised masked with the IRQ_ENABLE register. The register is read-only and the IRQ_ACK register should be used to clear individual interrupts. Table 2-18 and Table 2-19 describe the Interrupt Pending register.

Table 2-18: Interrupt Pending Register (IRQ_PENDING)

Reserved		INTC_Interrupt		Reserved	Internal Interrupts	
31	C_INTC_EXT_INTR+16	C_INTC_EXT_INTR+15	16	15	14	0

Table 2-19: Interrupt Pending Register Bit Definitions

Bit(s)	Name	Core Access	Reset Value	Description
31:[C_INTC_EXT_INTR+16]	-	R	0	Reserved
[C_INTC_EXT_INTR+15]:16	INTC_Interrupt	R	0	I/O Module external interrupt input signal INTC_Interrupt [C_INTC_EXT_INTR-1:0] mapped to corresponding bit positions in IRQ_STATUS
15	-	R	0	Reserved
14	GPI4	R	0	GPI4 changed
13	GPI3	R	0	GPI3 changed
12	GPI2	R	0	GPI2 changed
11	GPI1	R	0	GPI1 changed
10	FIT4	R	0	FIT4 strobe
9	FIT3	R	0	FIT3 strobe
8	FIT2	R	0	FIT2 strobe
7	FIT1	R	0	FIT1 strobe
6	PIT4	R	0	PIT4 expired
5	PIT3	R	0	PIT3 expired
4	PIT2	R	0	PIT2 expired
3	PIT1	R	0	PIT1 expired
2	UART_RX	R	0	UART Received Data
1	UART_TX	R	0	UART Transmitted Data
0	UART_ERR	R	0	UART Error

Interrupt Enable Register (IRQ_ENABLE)

The Interrupt Enable register enables assertion of the I/O Module core interrupt output signal INTC_IRQ by individual interrupt sources. The contents of this register are also used to mask the value of the IRQ_STATUS register when registering enabled interrupts in the IRQ_PENDING register. [Table 2-20](#) and [Table 2-21](#) describe the Interrupt Enable register.

Table 2-20: Interrupt Enable Register (IRQ_ENABLE)

Reserved	INTC_Interrupt	Reserved	Internal Interrupts
31 C_INTC_EXT_INTR+16	C_INTC_EXT_INTR+15 16	15	14 0

Table 2-21: Interrupt Enable Register Bit Definitions

Bit(s)	Name	Core Access	Reset Value	Description
31:[C_INTC_EXT_INTR+16]	-	-	0	Reserved
[C_INTC_EXT_INTR+15]:16	INTC_Interrupt	W	0	Enable I/O Module external interrupt input signal INTC_Interrupt(16-C_INTC_EXT_INTR)
15	-	-	0	Reserved
14	GPI4	W	0	GPI4 interrupt enabled
13	GPI3	W	0	GPI3 interrupt enabled
12	GPI2	W	0	GPI2 interrupt enabled
11	GPI1	W	0	GPI1 interrupt enabled
10	FIT4	W	0	FIT4 interrupt enabled
9	FIT3	W	0	FIT3 interrupt enabled
8	FIT2	W	0	FIT2 interrupt enabled
7	FIT1	W	0	FIT1 interrupt enabled
6	PIT4	W	0	PIT4 interrupt enabled
5	PIT3	W	0	PIT3 interrupt enabled
4	PIT2	W	0	PIT2 interrupt enabled
3	PIT1	W	0	PIT1 interrupt enabled
2	UART_RX	W	0	UART Received Data interrupt enabled
1	UART_TX	W	0	UART Transmitted Data interrupt enabled
0	UART_ERR	W	0	UART Error interrupt enabled

Interrupt Acknowledge Register (IRQ_ACK)

This register is used as a command register for clearing individual interrupts in IRQ_STATUS and IRQ_PENDING registers. All bits set to 1 clear the corresponding bits in the IRQ_STATUS and IRQ_PENDING registers. The register is write-only. [Table 2-22](#) and [Table 2-23](#) describe the Interrupt Acknowledge register.

Table 2-22: Interrupt Acknowledge Register (IRQ_ACK)

IRQ_ACK	
31	0

Table 2-23: Interrupt Acknowledge Register Bit Definitions

Bit(s)	Name	Core Access	Reset Value	Description
31:0	IRQ_ACK	W	0	All bit position written with 1 will clear corresponding bits in both the IRQ_STATUS and the IRQ_PENDING registers

Interrupt Mode Register (IRQ_MODE)

This register is used to define which interrupts use fast interrupt mode. All bits set to 1 use fast interrupt mode. The register is write-only. The register is only implemented when fast interrupt mode is enabled, by setting C_INTC_HAS_FAST to 1. [Table 2-24](#) and [Table 2-25](#) describe the Interrupt Mode register.

Table 2-24: Interrupt Mode Register (IRQ_MODE)

IRQ_MODE	
31	0

Table 2-25: Interrupt Mode Register Bit Definitions

Bit(s)	Name	Core Access	Reset Value	Description
31:0	IRQ_MODE	W	0	All bit positions written with 1 use fast interrupt mode

Interrupt Address Vector Registers (IRQ_VECTOR_0-IRQ_VECTOR_31)

These 32 registers are used as Interrupt Address Vector for the corresponding interrupt bit. The content is sent to the processor on the INTC_Interrupt_Address port when the interrupt occurs. The registers are write-only. [Table 2-26](#) and [Table 2-27](#) describe the Interrupt Address Vector register.

The two least significant bits and the most significant bits greater than or equal to C_INTC_ADDR_WIDTH (if any) of each register are fixed to 0.

For reserved interrupt bits (11-15), and unused external interrupts (greater than C_INTC_EXT_INTR+15), writing to the corresponding register has no effect.

The registers are only implemented when fast interrupt mode is enabled, by setting C_INTC_HAS_FAST to 1.

Table 2-26: Interrupt Address Vector Register (IRQ_VECTOR_x)

0		IRQ_VECTOR_x	0
31	C_INTC_ADDR_WIDTH	C_INTC_ADDR_WIDTH-1	2 1 0

Table 2-27: Interrupt Address Vector Register Bit Definitions

Bit(s)	Name	Core Access	Reset Value	Description
31:0	IRQ_VECTOR	W	(1)	The Interrupt Address Vector for the corresponding interrupt.

1. C_INTC_BASE_VECTORS + 0x10

PITx Preload Register (PITx_PRELOAD) (x = 1, 2, 3 or 4)

The value written to this register determines the initial value of the counter. In continuous mode the counter is reloaded with the value of this register. The period is the value written to the register + 2 count events. The register is implemented if C_USE_PITx is 1. [Table 2-28](#) and [Table 2-29](#) describe the PITx Preload register.

Table 2-28: PITx Preload Register (PITx_PRELOAD)

	Reserved	PITx_PRELOAD
31	C_PITx_SIZE	C_PITx_SIZE-1 0

Table 2-29: PITx Preload Register Bit Definitions

Bit(s)	Name	Core Access	Reset Value	Description
31:C_PITx_SIZE	-	-	-	Reserved
[C_PITx_SIZE-1]:0	PITx_PRELOAD	W	0	Register holds the timer period

PITx Counter Register (PITx_COUNTER) (x = 1, 2, 3 or 4)

When reading this register the data obtained is a sample of the current counter value. The register is implemented if C_USE_PITx is 1 and C_PITx_READABLE is 1. [Table 2-30](#) and [Table 2-31](#) describe the PITx Counter register.

Table 2-30: PITx Counter Register (PITx_COUNTER)

Reserved		PITx_PRELOAD	
31	C_PITx_SIZE	C_PITx_SIZE-1	0

Table 2-31: PITx Counter Register Bit Definitions

Bit(s)	Name	Core Access	Reset Value	Description
31:C_PITx_SIZE	-	-	-	Reserved
[C_PITx_SIZE-1]:0	PITx_COUNTER	R	0	PITx counter value at time of read

PITx Control Register (PITx_CONTROL) (x=1, 2, 3 or 4)

The EN bit in this register enables/disables counting. The PRELOAD bit determines if the counting is continuous with automatic reload of the PITx_PRELOAD value when it expires. The register is implemented if C_USE_PITx is 1. [Table 2-32](#) and [Table 2-33](#) describe the PITx Control register.

Table 2-32: PITx Control Register (PITx_CONTROL)

Reserved		RELOAD	EN
31	2	1	0

Table 2-33: PITx Control Register Bit Definitions

Bit(s)	Name	Core Access	Reset Value	Description
31:2	-	-	0	Reserved
1	PRELOAD	W	0	0 = Counter counts past zero and then stops 1 = Counter value is automatically reloaded with the PITx_PRELOAD value when counter expires
0	EN	W	0	0 = Counting Disabled 1 = Counter Enabled

Designing with the Core

This chapter includes guidelines and additional information to facilitate designing with the core.

General Design Guidelines

I/O Bus

The I/O bus provides a simple bus for accessing to external modules using MicroBlaze™ Load/Store instructions. The I/O bus is mapped at address C_IO_BASEADDR–C_IO_HIGHADDR in the MicroBlaze memory space, with the I/O bus address directly reflecting the byte address used by MicroBlaze Load/Store instructions. I/O bus data is 32-bit wide, with byte enables to write byte and half-word data.

The I/O bus has a ready handshake to handle different waitstate needs, from IO_Ready asserted the cycle after the IO_Addr_Strobe is asserted to as many cycles as needed. There is no timeout on the I/O bus and MicroBlaze is stalled until IO_Ready is asserted. IO_Address, IO_Byte_Enable, IO_Write_Data, IO_Read_Strobe, IO_Write_Strobe are only valid when IO_Addr_Strobe is asserted. For read access IO_Read_Data is sampled at the rising Clk edge, when the slave has asserted IO_Ready.

I/O bus read and write transactions can be found in the two following timing diagrams in [Figure 3-1](#) and [Figure 3-2](#).

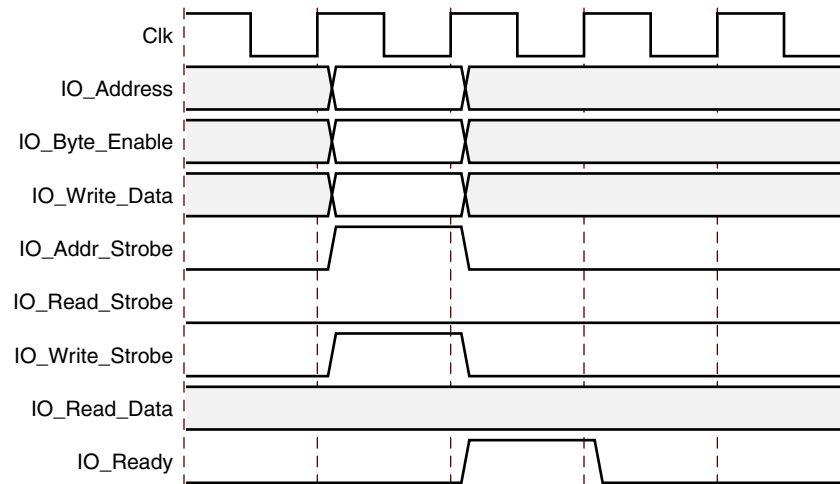

Figure 3-1: I/O Bus Write

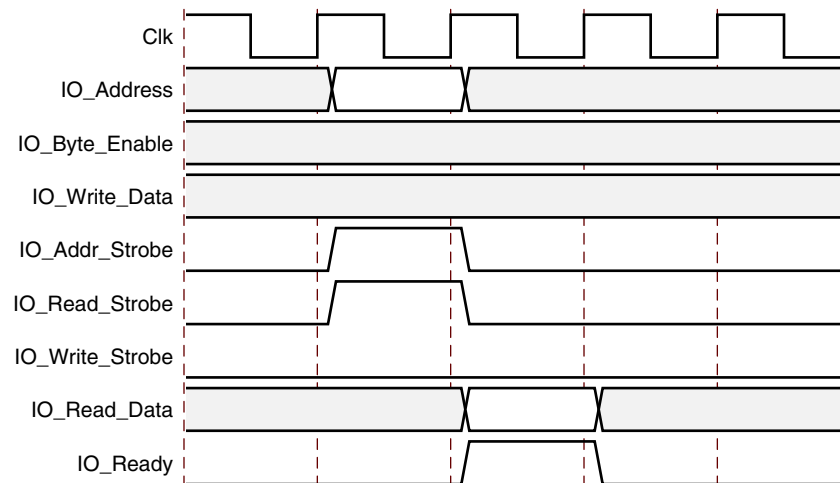

Figure 3-2: I/O Bus Read

The byte enable signals indicate which byte lanes of the data bus contain valid data. Valid values for IO_Byte_Enable are shown in [Table 3-1](#). The IO_Byte_Enable signal should be used instead of the two least significant bits of the IO_Address to decode byte and halfword accesses, to ensure that byte and halfword accesses are correctly decoded independent of MicroBlaze endianness.

Table 3-1: Valid Values for IO_Byte_Enable[3:0]

IO_Byte_Enable	IO_Data_Write and IO_Data_Read Byte Lanes Used				
	[3:0]	[31:24]	[23:16]	[15:8]	[7:0]
0001					
0010					
0100					
1000					
0011					
1100					
1111					

The I/O bus is fully compatible with the Xilinx Dynamic Reconfiguration Port (DRP). This configuration port supports partial dynamic reconfiguration of functional blocks, such as CMTs, clock management, XADC, serial transceivers, and the PCIe® block.

The nominal connection of the I/O bus to the DRP is shown in [Table 3-2](#).

Table 3-2: Mapping of the I/O Bus to the Dynamic Reconfiguration Port

I/O Module Signal	DRP Signal	Note
Clk	DCLK	
IO_Addr_Strobe	DEN	
IO_Read_Strobe	-	Not used by DRP
IO_Write_Strobe	DWE	
IO_Address[m+2:2]	DADDR[m:0]	Uses 32-bit word access for DRP
IO_Byte_Enable	-	Only 32-bit word accesses used for DRP
IO_Write_Data[n:0]	DI[n:0]	Data width depends on DRP (n < 32)
IO_Read_Data[n:0]	DO[n:0]	Data width depends on DRP (n < 32)
IO_Ready	DRDY	

For a detailed description of the DRP, see the *7 Series FPGAs Configuration User Guide* (UG740) [\[Ref 2\]](#).

UART

The Universal Asynchronous Receiver Transmitter (UART) interface provides the controller interface for asynchronous serial data transfers. Features supported include:

- One transmit and one receive channel (full duplex)
- Configurable number of data bits in a character (5-8)
- Configurable parity bit (odd or even)
- Configurable and programmable baud rate

The UART performs parallel-to-serial conversion on characters received through LMB and serial-to-parallel conversion on characters received from a serial peripheral. The UART is capable of transmitting and receiving 8, 7, 6 or 5-bit characters, with 1-stop bit and odd, even or no parity. The UART can transmit and receive independently.

The device can be configured and its status can be monitored via the internal register set. The UART also asserts the `UART_Interrupt` output when the receiver becomes non-empty, when the transmitter becomes empty or when an error condition has occurred. The individual interrupt events are connected to the Interrupt Controller of the I/O Module core and can be used to assert the `INTC_IRQ` output signal.

The UART can be configured with either fixed or programmable baud rate. When using programmable baud rate the `UART_BAUD` register is used to set the baud rate. The initial value of this register is determined from the selected fixed baud rate. The register value is calculated by the formula:

$$\text{UART_BAUD} = \frac{\text{Clock Frequency of Clk (Hz)}}{\text{Baud Rate} \bullet 16} - 1$$

Fixed Interval Timer, FIT

The Fixed Interval Timer generates a strobe (interrupt) signal at fixed intervals. The Fixed Interval Timer asserts the output signal `FITx_Interrupt` one clock cycle every `C_FITx_NO_CLOCKS`. Operation begins immediately after FPGA configuration and the clock is running. The `FITx_Toggle` output signal is toggled each time `FITx_Interrupt` is asserted, creating a 50% duty cycle output with twice the `FITx_Interrupt` period. Using the parameter `C_FITx_INTERRUPT`, the FIT can be connected to the Interrupt Controller of the I/O Module core and used for generating interrupts every time the strobe occurs.

Programmable Interval Timer, PIT

The Programmable Interval Timer, PIT, has a configurable width from 1 to 32. The PIT operation and period are controlled by software.

The `PITx_Interrupt` output signal is asserted one clock cycle when the timer expires. The timer can be used in continuous mode, where the timer reloads automatically when it expires. In continuous mode, the period between two `PITx_Interrupt` assertions is the value in PITx Preload Register + 2 count events.

The PIT can also be used in one-shot mode, where the timer stops when it has counted down past zero. The timer is implemented by means of a counter that is pre-loaded with the timer value and then decremented. When the counter passes zero, the timer expires, and the interrupt signal is generated. The timer starts counting when it is enabled by setting the EN bit in the PITx Control Register.

The `PITx_Toggle` output signal is toggled each time `PITx_Interrupt` is asserted, creating a 50% duty cycle output with twice the `PITx_Interrupt` period when the timer is operated in continuous mode.

The value of the counter that implements the timer can be read by software if the `C_PITx_Readable` parameter is enabled. The PIT can have a pre-scaler connected from any FITx, PITx, or External. The pre-scaler is selected by the `C_PITx_PRESCALER` parameter. The PIT has no pre-scaler by default. If External is selected the input signal `PITx_Enable` is used as pre-scaler. Selecting External as pre-scaler can also be used to measure the width in clock cycles of a signal connected to the `PITx_Enable` input.

Using the parameter `C_PITx_INTERRUPT`, the PIT can be connected to the Interrupt Controller of the I/O Module core and used for generating interrupts every time it expires.

General Purpose Output, GPO

The General Purpose Output, GPO, drives I/O Module GPO output signals defined by the value of the `GPOx` register, programmable from software. The width of the `GPOx` is defined by the `C_GPOx_SIZE` and the initial value is defined by the parameter `C_GPOx_INIT`. When the `GPOx` register is written, the value of the `GPOx` output signals change accordingly.

General Purpose Input, GPI

The General Purpose Input, GPI, makes it possible for software to sample the value of the I/O Module GPI input signals by reading the `GPIx` register. The width of `GPIx` is defined by the parameter `C_GPIx_SIZE`.

Using the parameter `C_GPIx_INTERRUPT`, the GPI can be connected to the Interrupt Controller of the I/O Module core and used for generating interrupts every time an input changes (both edges), every time it changes from 0 to 1 (rising edge), or every time it changes from 1 to 0 (falling edge).

Interrupt Controller INTC

The Interrupt Controller handles both I/O module internal interrupt events and external ones. The internal interrupt events originate from the UART, the Fixed Interval Timers, the Programmable Interval Timers, or the General Purpose Inputs. For an internal interrupt to be generated on the `INTC_IRQ` output, the corresponding I/O Module core parameter needs to be set, for example, `C_UART_RX_INTERRUPT=1`, and that particular interrupt needs to be enabled in the Interrupt Enable Register.

The Interrupt Controller supports up to 16 external interrupts using the `INTC_Interrupt` inputs. The number of external interrupts is defined by the parameter, `C_INTC_INTR_SIZE`. The external interrupt signals can be individually configured as either edge or level sensitive by the `C_INTC_LEVEL_EDGE` parameter. The polarity of the external interrupt signals can be individually configured to be either active-High (rising edge) or Low (falling edge) by the `C_INTC_POSITIVE` parameter. Interrupt events for external interrupt sources are generated according to [Table 3-3](#).

Table 3-3: Interrupt Event Generation

C_INTC_LEVEL_EDGE(x)	C_INTC_POSITIVE(x)	INTC_Interrupt(x) Input
0	0	0
0	1	1
1	0	1 -> 0
1	1	0 -> 1
0	0	0

The current status of all interrupt sources can be read from the Interrupt Status Register. The current status of all enabled interrupts can be read from the Interrupt Pending Register.

An interrupt is cleared in both the Interrupt Status and Interrupt Pending Registers by writing to the Interrupt Acknowledge Register, with bits set corresponding to the interrupts that should be cleared.

Either normal or fast interrupt mode can be used, based on latency requirement. Fast interrupt mode is available when the parameter C_INTC_HAS_FAST is set, and is enabled for an interrupt by setting the corresponding bit in the Interrupt Mode Register (IRQ_MODE). In this case, the Interrupt Controller drives the interrupt vector address of the highest priority interrupt on the INTC_Interrupt_Address port, along with INTC_IRQ. The generated interrupt is cleared based on acknowledge received from the processor through the INTC_Interrupt_Ack port. The processor sends 0b01 on this port when the interrupt is being acknowledged by the processor (that is, when branching to the interrupt service routine), sends 0b10 when executing a return from interrupt instruction in the interrupt service routine, and sends 0b11 when interrupts are re-enabled. The bit in IRQ_STATUS corresponding to the interrupt is cleared when 0b10 or 0b11 is seen on the port.

With fast interrupt mode, the interrupt vector address for each interrupt is stored in the corresponding IRQ_VECTOR register. To be compatible with normal mode, the registers are initialized to C_INTC_BASE_VECTORS + 0x10 after reset, which is equivalent to the static interrupt vector used by normal mode.

LMB Timing

See the MicroBlaze Bus Interfaces chapter in the *MicroBlaze Processor Reference Guide* (UG984) [Ref 1] for details on the transaction signaling.

Clocking

The I/O Module core is fully synchronous with all clocked elements clocked with the CLK input.

Resets

The `Rst` input is the master reset input signal for the I/O Module core.

When Triple Modular Redundancy is use the additional `TMR_Rst` input signal provides the option to only reset the flip-flops that are not majority voted, to support TMR recovery.

Protocol Description

See the LMB Interface Description timing diagrams in the *MicroBlaze Processor Reference Guide* (UG984) [Ref 1].

Design Flow Steps

This chapter describes customizing and generating the core, constraining the core, and the simulation, synthesis and implementation steps that are specific to this IP core. More detailed information about the standard Vivado® design flows and the IP integrator can be found in the following Vivado Design Suite user guides:

- *Vivado Design Suite User Guide: Designing IP Subsystems using IP Integrator* (UG994) [\[Ref 4\]](#)
- *Vivado Design Suite User Guide: Designing with IP* (UG896) [\[Ref 5\]](#)
- *Vivado Design Suite User Guide: Getting Started* (UG910) [\[Ref 6\]](#)
- *Vivado Design Suite User Guide: Logic Simulation* (UG900) [\[Ref 7\]](#)

Customizing and Generating the Core

This chapter includes information on using Xilinx tools to customize and generate the core in the Vivado Design Suite.

If you are customizing and generating the core in the Vivado IP integrator, see the *Vivado Design Suite User Guide: Designing IP Subsystems using IP Integrator* (UG994) [\[Ref 4\]](#) for detailed information. IP integrator might auto-compute certain configuration values when validating or generating the design. To check whether the values do change, see the description of the parameter in this chapter. To view the parameter value you can run the `validate_bd_design` command in the Tcl console.

You can customize the IP for use in your design by specifying values for the various parameters associated with the IP core using the following steps:

1. Select the IP from the IP catalog.
2. Double-click the selected IP or select the Customize IP command from the toolbar or right-click menu.

For details, see the *Vivado Design Suite User Guide: Designing with IP* (UG896) [\[Ref 5\]](#) and the *Vivado Design Suite User Guide: Getting Started* (UG910) [\[Ref 6\]](#).

Note: Figures in this chapter are illustrations of the Vivado IDE. This layout might vary from the current version.

The I/O Module core parameters are divided into eight tabs in the Vivado Integrated Design Environment (IDE): Board, System, UART, FIT Timers, PIT Timers, GPO, GPI and Interrupt. When using Vivado IP integrator, the addresses and masks are auto generated.

The Board tab is shown in [Figure 4-1](#).

The board tab is only visible when a board has been defined for the project being used.

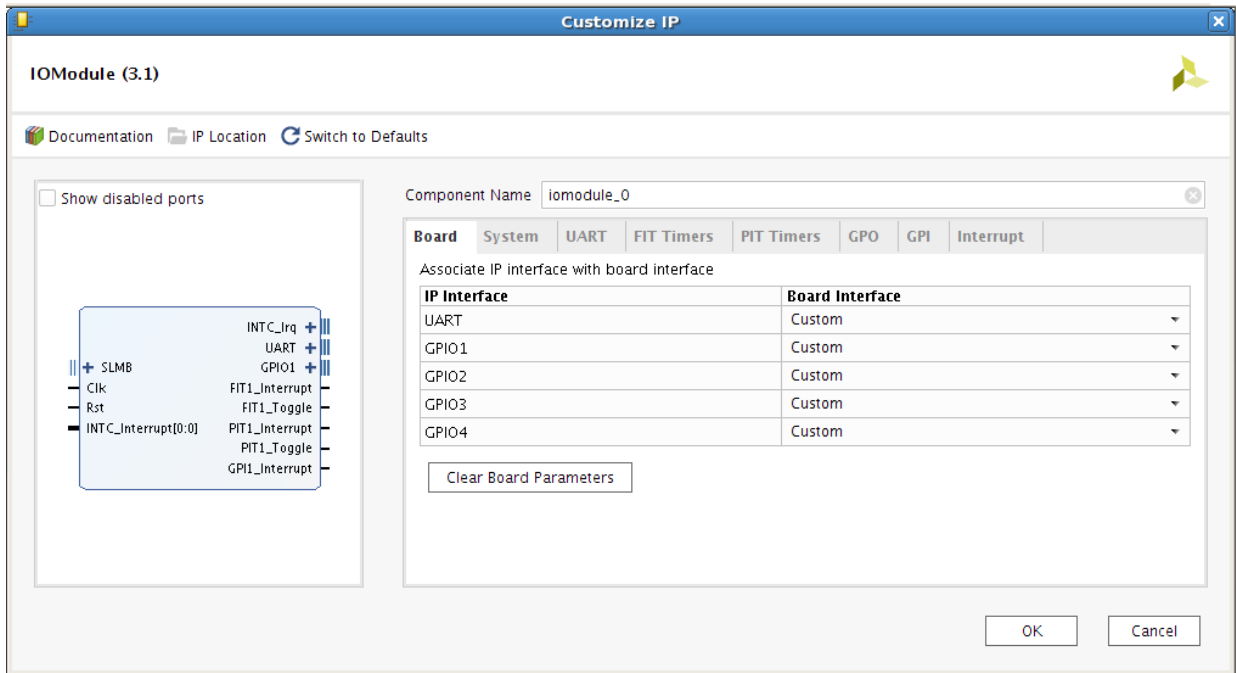

Figure 4-1: Board Tab

Generate Board Based IO Constraints - Enable board specific GPI, GPO, and UART interfaces. Board constraints are automatically generated for the selected interfaces.

Associate IP interface with board interface - Table to select board interface for GPIO1, GPIO2, GPIO3, GPIO4 or UART interface.

The System tab is shown in Figure 4-2.

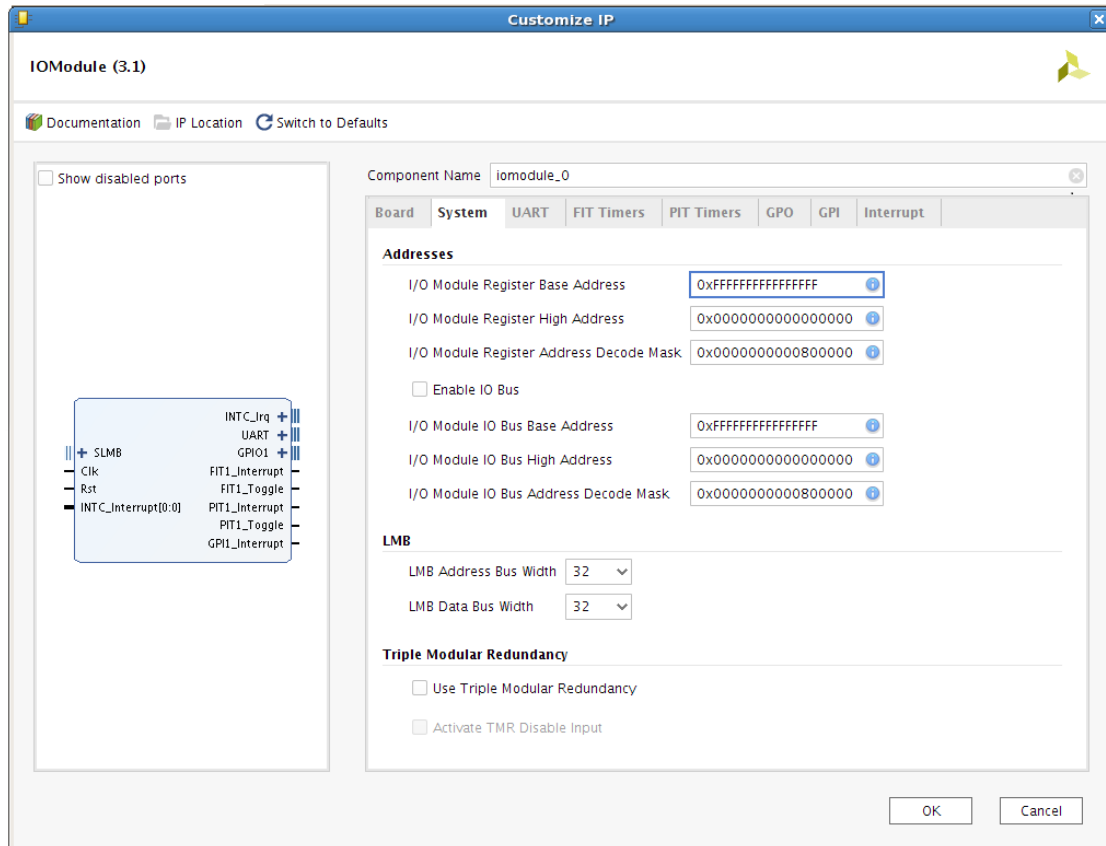

Figure 4-2: System Tab

- **I/O Module Register Base Address** - Base address of the internal registers with up to 64 bits.
- **I/O Module Register High Address** - High address of the internal registers with up to 64 bits.
- **I/O Module Register Address Decode Mask** - A mask indicating which address bits the module takes into account when decoding a register access with up to 64 bits. When using IP integrator, Vivado automatically computes the value of this parameter based on the address space of the connected processor.
- **Enable IO Bus** - Enables the I/O bus to connect to DRP or external peripherals.
- **I/O Module IO Bus Base Address** - Base address of the I/O bus with up to 64 bits.
- **I/O Module IO Bus High Address** - High address of the I/O bus with up to 64 bits.
- **I/O Module IO Bus Address Decode Mask** - A mask indicating which address bits the module takes into account when decoding an I/O bus access with up to 64 bits. When using IP integrator, Vivado automatically computes the value of this parameter based on the address space of the connected processor.

- **Use Triple Modular Redundancy** - Enable support for use in a Triple Modular Redundant (TMR) subsystem. When this parameter is set, the internal state is voted between this core and the two other cores in the subsystem, to ensure that single errors are corrected.
- **Activate TMR Disable Input** - Activate TMR disable functionality. When activated and the TMR_Disable input is set to one, the inputs from other I/O Modules are disregarded.

The UART parameter tab is shown in [Figure 4-3](#).

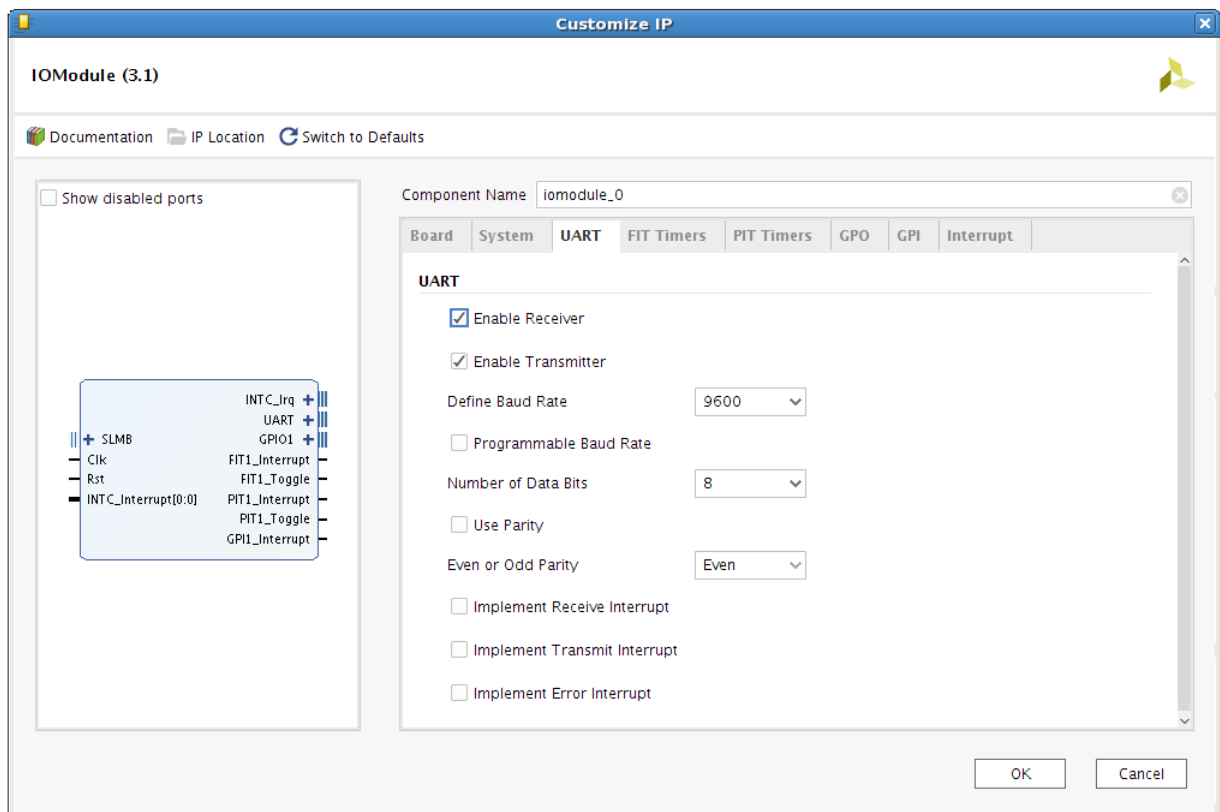

Figure 4-3: UART Parameter Tab

- **Enable Receiver** - Enables UART receiver for character input. This is automatically connected to standard input (`stdin`) in the software program.
- **Enable Transmitter** - Enables UART transmitter for character output. This is automatically connected to standard output (`stdout`) in the software program.
- **Define Baud Rate** - Sets the UART baud rate. To get the correct baud rate, the input clock frequency must also be correctly defined.
- **Programmable Baud Rate** - Determines if the UART baud rate is programmable. The default baud rate is calculated based on the input clock frequency and the defined baud rate.

- **Number of Data Bits** - Defines the number of data bits used by the UART. Should almost always be set to 8.
- **Use Parity** - Enable this parameter to use parity checking of the UART characters.
- **Even or Odd Parity** - Select odd or even parity. Only available when parity is used.
- **Implement Receive Interrupt** - Generate an interrupt when the UART has received a character. When the interrupt is not enabled the UART must be polled to check if data has been received.
- **Implement Transmit Interrupt** - Generate an interrupt when the UART has sent a character. When the interrupt is not enabled the UART must be polled to wait until data has been transmitted.
- **Implement Error Interrupt** - Generate an interrupt if an error occurs when the UART receives a character. This error can be a framing error, an overrun error or a parity error (if parity is used), When the interrupt is not enabled the UART must be polled to check if an error has occurred after a character has been received.

The FIT Timer parameter tab showing the parameters for one of the four timers is illustrated in [Figure 4-4](#).

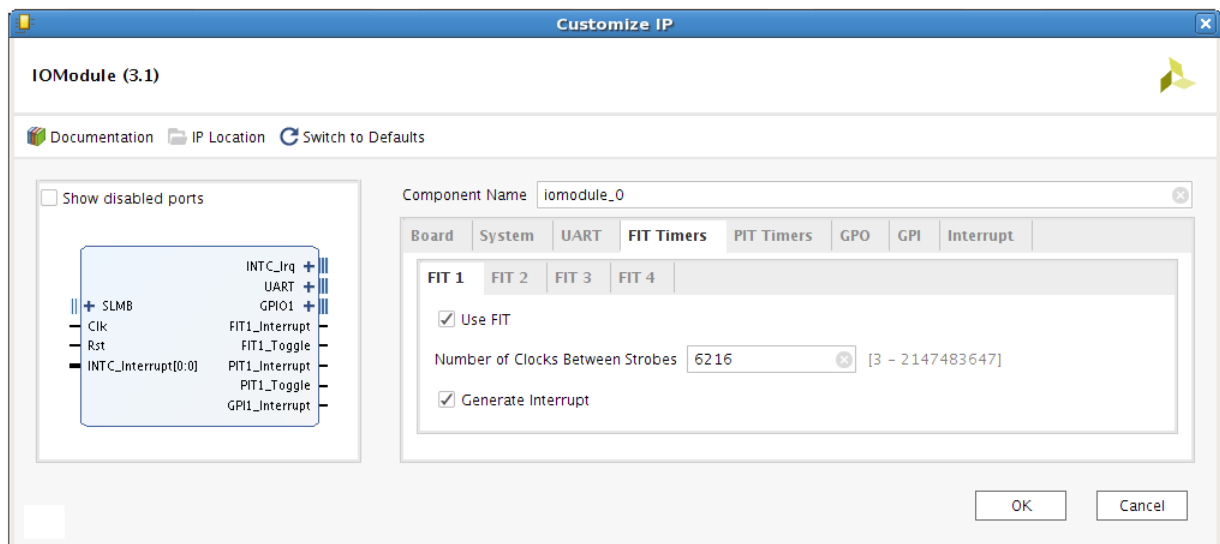

Figure 4-4: FIT Timers Parameter Tab

- **Use FIT** - Enable the Fixed Interval Timer.
- **Number of Clocks Between Strokes** - The number of clock cycles between each strobe.
- **Generate Interrupt** - Generate an interrupt for each Fixed Interval Timer strobe.

The PIT Timer parameter tab showing the parameters for one of the four timers is illustrated in Figure 4-5.

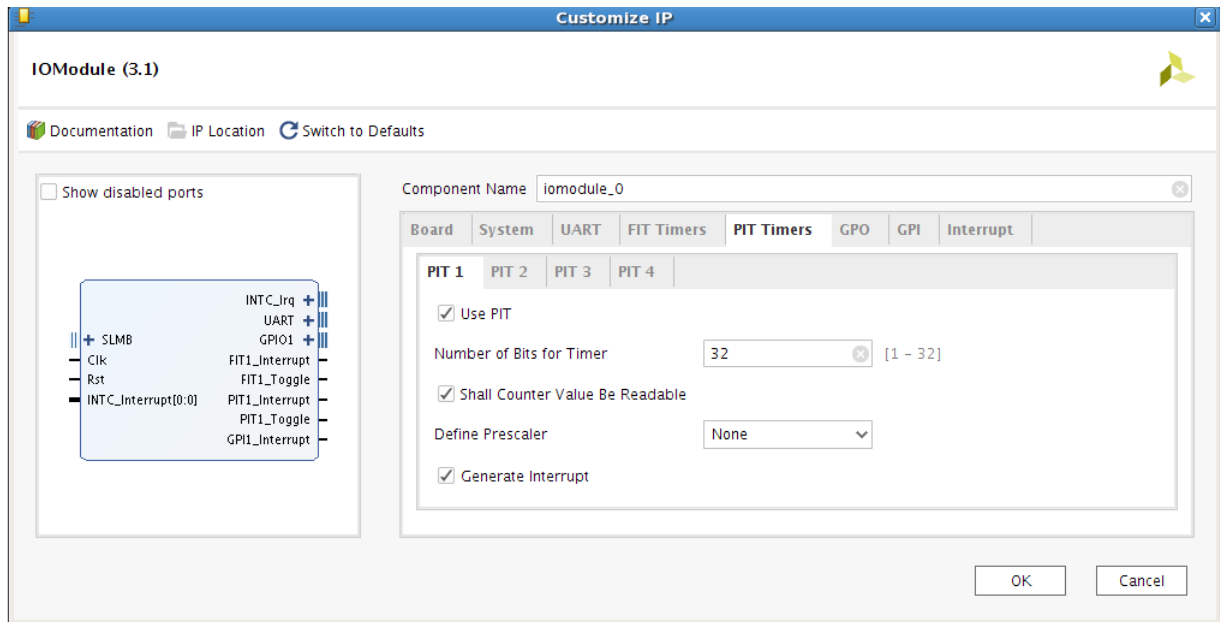

Figure 4-5: PIT Timers Parameter Tab

- **Use PIT** - Enable the Programmable Interval Timer.
- **Number of Bits for Timer** - The maximum number of bits used for the counter value.
- **Shall Counter Value be Readable** - The Programmable Interval Timer counter is readable by software when this parameter is set. Unless resource usage is critical it is recommended that this is kept enabled.
- **Define Prescaler** - Selects a prescaler as source for the Programmable Interval Timer count. When no prescaler is selected the core input clock is used. Any Programmable Interval Timer or Fixed Interval Timer can be used as prescaler, as well as a dedicated external enable input.
- **Generate Interrupt** - Generate an interrupt when the Programmable Interval Timer has counted down to zero.

The GPO parameter tab showing the parameters for the four General Purpose Output ports is illustrated in Figure 4-6.

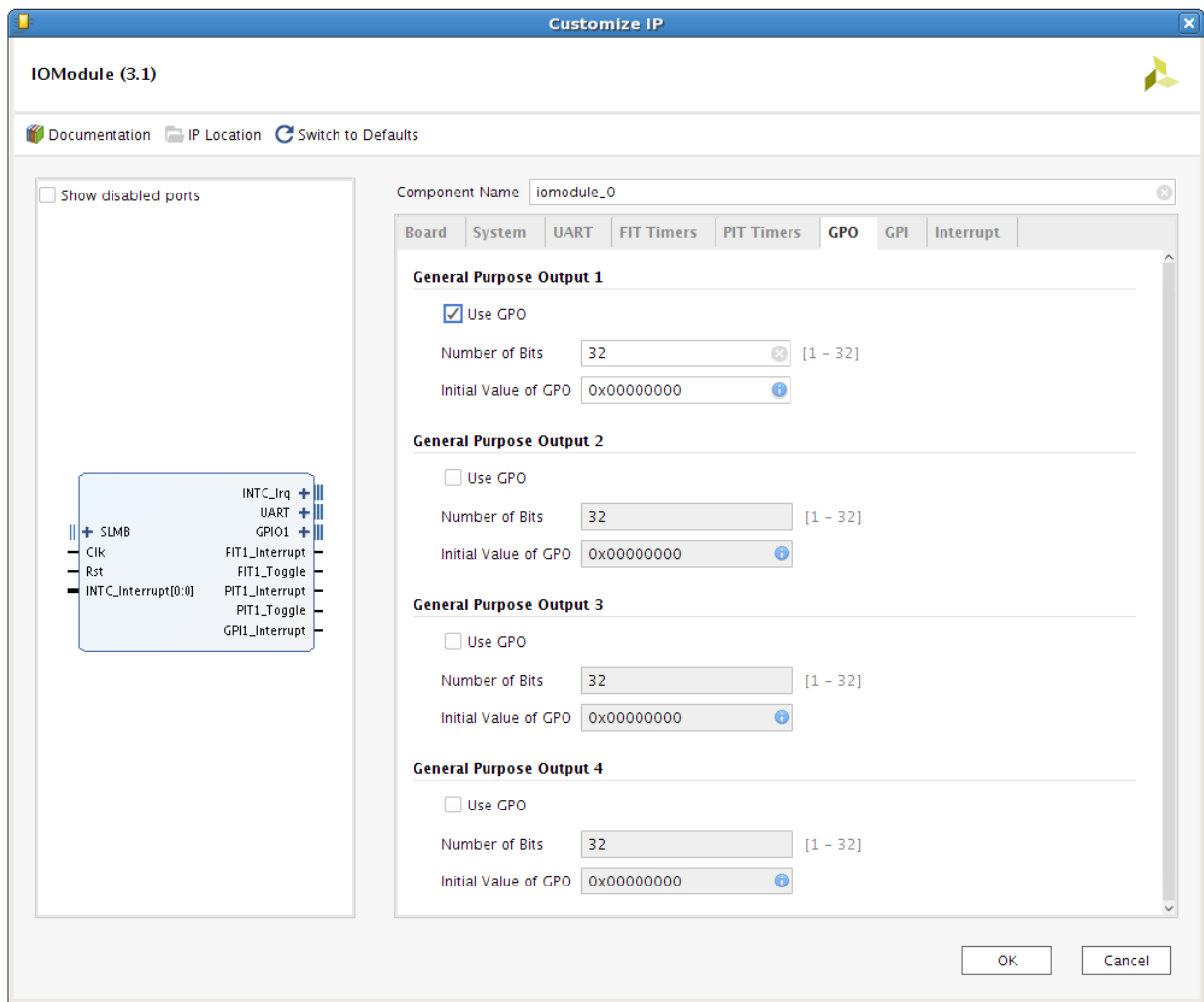

Figure 4-6: GPO Parameter Tab

- **Use GPO** - Enable the General Purpose Output port.
- **Number of Bits** - Set the number of bits of the General Purpose Output port.
- **Initial Value of GPO** - Set the initial value of the General Purpose Output port. The right most bit in the value is assigned to bit 0 of the port, the next right most to bit 1, and so on.

The GPI parameter tab showing the parameters for the four General Purpose Input ports is illustrated in Figure 4-7.

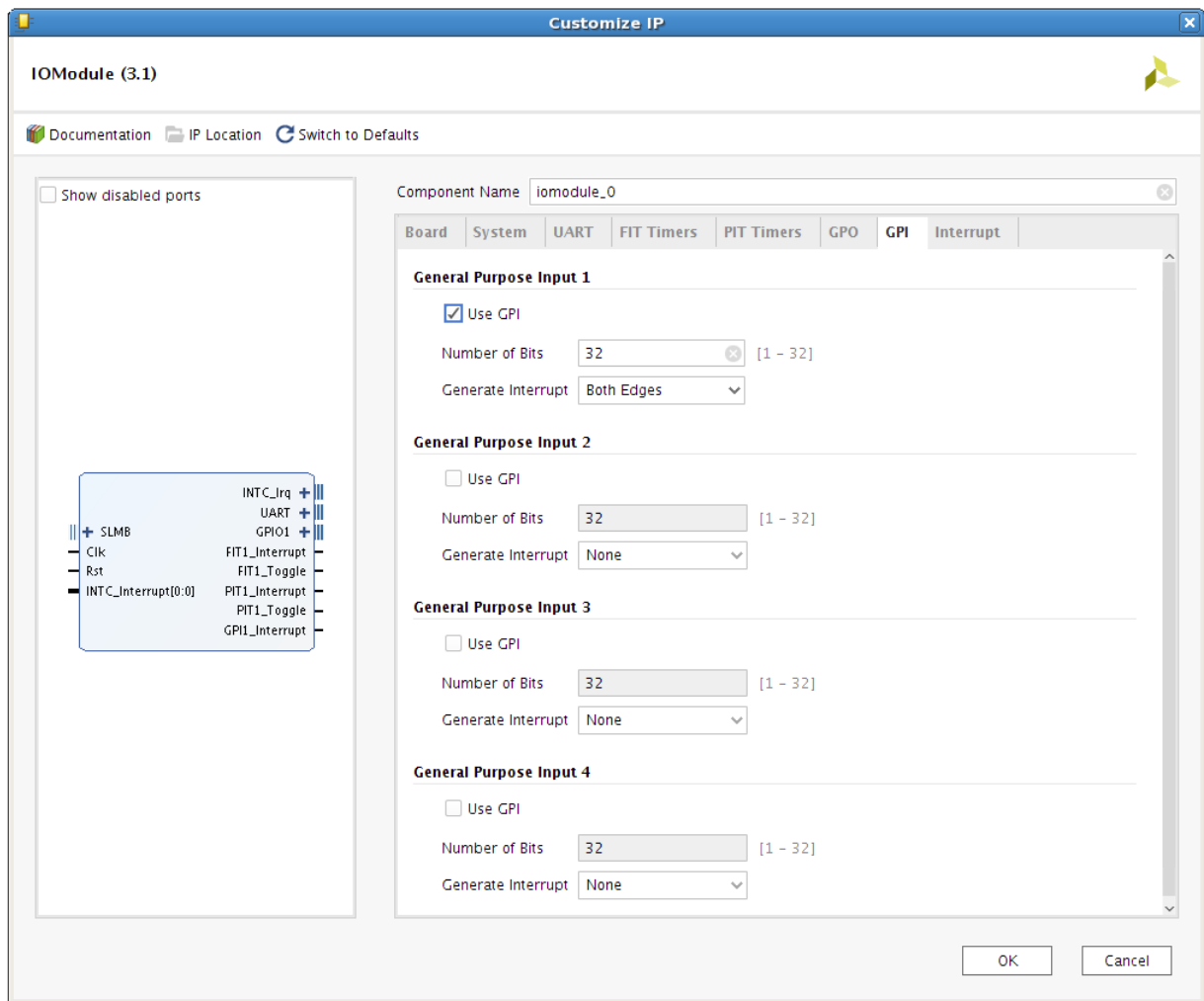

Figure 4-7: GPI Parameter Tab

- **Use GPI** - Enable the General Purpose Input port.
- **Number of Bits** - Set the number of bits of the General Purpose Input port.
- **Generate Interrupt** - Generate an interrupt when a General Purpose Input changes in the specified way - either any change (Both Edges), only when changed from 0 to 1 (Rising Edge), or only when changed from 1 to 0 (Falling Edge).

The Interrupt parameter tab is shown in Figure 4-8.

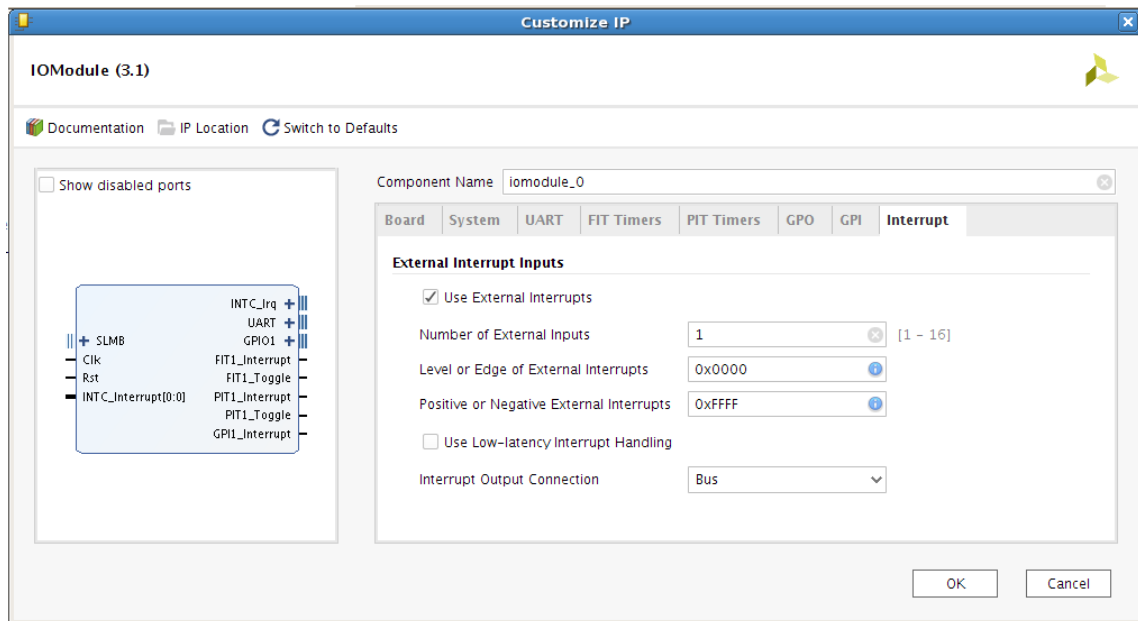

Figure 4-8: Interrupt Parameter Tab

- **Use External Interrupts** - Enable the use of external interrupt inputs.
- **Number of External Inputs** - Select the number of used external interrupt inputs.
- **Level or Edge of External Interrupts** - Select whether the input is considered level sensitive or edge triggered. Each bit in the value corresponds to the equivalent interrupt input. When a bit is set to one, the interrupt is edge triggered, otherwise it is level sensitive.

In IP integrator, this value is normally automatically determined from the connected interrupt signals, but can be set manually if necessary.

- **Positive or Negative External Interrupts** - Set whether to use high or low level for level sensitive interrupts, and rising or falling edge for edge triggered interrupts. Each bit in the value corresponds to the equivalent interrupt input. When a bit is set to one, high level or rising edge is used, otherwise low level or falling edge is used.

In IP integrator, this value is normally automatically determined from the connected interrupt signals, but can be set manually if necessary.

- **Use Low-latency Interrupt Handling** - Enable the use of low-latency interrupt handling.
- **Interrupt Output Connection** - Select interrupt output connection bus interface. Normally **Bus** is used when connecting to MicroBlaze. Otherwise **Single** can be used when low-latency interrupt handling is not enabled, and the target has a single interrupt input.

Parameter Values

To obtain an I/O Module core that is uniquely tailored a specific system, certain features can be parameterized in the I/O module design. This allows for configuring a design that only uses the resources required by the system, and operates with the best possible performance. The features that can be parameterized in I/O Module designs are shown in [Table 4-1](#).

Table 4-1: I/O Module Parameters

Parameter Name	Feature/Description	Allowable Values	Default Value	VHDL Type
C_FAMILY ⁽¹⁾	FPGA Architecture	Supported architectures	virtex7	string
I/O Bus Parameter				
C_USE_IO_BUS	Use I/O bus	0 = Not Used 1 = Used	0	integer
UART Parameters				
C_USE_UART_RX	Use UART Receive	0 = Not Used 1 = Used	0	integer
C_USE_UART_TX	Use UART Transmit	0 = Not Used 1 = Used	0	integer
C_UART_BAUDRATE	Baud rate of the UART in bits per second	integer (e.g. 115200)	9600	integer
C_UART_PROG_BAUDRATE	Programmable UART Baud rate	0 = Not Used 1 = Used	0	integer
C_UART_DATA_BITS	The number of data bits in the serial frame	5 - 8	8	integer
C_UART_USE_PARITY	Determines whether parity is used or not	0 = No Parity 1 = Use Parity	0	integer
C_UART_ODD_PARITY	If parity is used, determines whether parity is odd or even	0 = Even Parity 1 = Odd Parity	0	integer
C_UART_RX_INTERRUPT	Use UART RX Interrupt in INTC	0 = Not Used 1 = Used	0	integer
C_UART_TX_INTERRUPT	Use UART TX Interrupt in INTC	0 = Not Used 1 = Used	0	integer
C_UART_ERROR_INTERRUPT	Use UART ERROR Interrupt in INTC	0 = Not Used 1 = Used	0	integer
FIT Parameters				
C_USE_FITx ⁽²⁾	Enable implementation of FIT	0 = Not Used 1 = Used	0	integer
C_FITx_No_CLOCKS ⁽²⁾	The number of clock cycles between strobes	>2	6216	integer
C_FITx_INTERRUPT ⁽²⁾	Use FITx_Interrupt in INTC	0 = Not Used 1 = Used	0	integer

Table 4-1: I/O Module Parameters (Cont'd)

Parameter Name	Feature/Description	Allowable Values	Default Value	VHDL Type
PIT Parameters				
C_USE_PITx ⁽²⁾	Enable implementation of PIT	0 = Not Used 1 = Used	0	integer
C_PITx_SIZE ⁽²⁾	Size of PITx counter	1 - 32	1	integer
C_PITx_READABLE ⁽²⁾	Make PITx counter software readable	0 = Not SW readable 1 = SW readable	1	integer
C_PITx_PRESCALER ⁽²⁾⁽³⁾	Select PITx prescaler	0 = No prescaler 1 = FIT1 2 = FIT2 3 = FIT3 4 = FIT4 5 = PIT1 6 = PIT2 7 = PIT3 8 = PIT4 9 = External	0	integer
C_PITx_INTERRUPT ⁽²⁾	Use PITx_Interrupt in INTC	0 = Not Used 1 = Used	0	integer
GPO Parameters				
C_USE_GPOx ⁽²⁾	Use GPOx	0 = Not Used 1 = Used	0	integer
C_GPOx_SIZE ⁽²⁾	Size of GPOx	1 - 32	32	integer
C_GPOx_INIT ⁽²⁾	Initial value for GPOx	Fit Range (31:0)	all zeros	std_logic_vector
GPI Parameters				
C_USE_GPIx ⁽²⁾	Use GPIx	0 = Not Used 1 = Used	0	integer
C_GPIx_SIZE ⁽²⁾	Size of GPIx	1 - 32	32	integer
C_GPIx_INTERRUPT ⁽²⁾	Use GPIx_Interrupt in INTC	0 = None 1 = Both Edges 2 = Rising Edge 3 = Falling Edge	0	integer
INTC Parameters				
C_INTC_USE_EXT_INTR	Use I/O Module external interrupt inputs	0 = Not Used 1 = Used	0	integer
C_INTC_INTR_SIZE	Number of external interrupt inputs used	1 - 16	1	integer
C_INTC_LEVEL_EDGE	Level or edge triggered for each external interrupt	For each bit: 0 = Level 1 = Edge	level	std_logic_vector

Table 4-1: I/O Module Parameters (Cont'd)

Parameter Name	Feature/Description	Allowable Values	Default Value	VHDL Type
C_INTC_POSITIVE	Polarity for each external interrupt	For each bit: 0 = active-Low 1 = active-High	active-High	std_logic_vector
C_INTC_HAS_FAST	Use fast interrupt mode	0 = Not Used 1 = Used	0	integer
C_INTC_ADDR_WIDTH	Interrupt Address width	5 - 32	32	integer
C_INTC_BASE_VECTORS	Relocatable base vector address	0x00000000 - 0xFFFFF80 ⁽⁴⁾	0x00000000	std_logic_vector
C_INTC_ASYNC_INTR ⁽¹⁾	Asynchronous interrupt for each external interrupt	For each bit: 0 = Synchronous 1 = Asynchronous	Asynchronous	std_logic_vector
C_INTC_NUM_SYNC_FF ⁽¹⁾	Number of synchronization flip-flops	0 - 7	2	integer
C_INTC_IRQ_CONNECTION	Bus or Single interrupt output connection	0 = Bus 1 = Single	0	integer
C_INTC_USE_IRQ_OUT ⁽⁵⁾	Enable extra interrupt output	0 = Disabled 1 = Enabled	0	integer
TMR Parameters				
C_TMR	Use Triple Modular Redundancy	0 = Not Used 1 = Used	0	integer
C_USE_TMR_DISABLE	Activate TMR Disable input	0 = Not activated 1 = Activated	0	integer

Notes:

1. Values automatically populated by tool.
2. x = 1, 2, 3 or 4.
3. Selecting PIT prescaler the same as PITx is illegal, e.g. PIT2 cannot be prescaler to itself.
4. The 7 least significant bits must all be 0.
5. Parameter not available in the Customize IP dialog.

User Parameters

Table 4-2 shows the relationship between the fields in the Vivado IDE and the User Parameters (which can be viewed in the Tcl console).

Table 4-2: Vivado IDE Parameter to User Parameter Relationship

Vivado IDE Parameter	User Parameter	Default Value
I/O Module Register Base Address	C_BASEADDR	0xFFFFFFFF
I/O Module Register High Address	C_HIGHADDR	0x00000000
I/O Module Register Address Decode Mask	C_MASK	0x00800000
Enable IO Bus	C_USE_IOBUS	0

Table 4-2: Vivado IDE Parameter to User Parameter Relationship (Cont'd)

Vivado IDE Parameter	User Parameter	Default Value
I/O Module IO Bus Base Address	C_IO_BASEADDR	0xFFFFFFFF
I/O Module IO Bus High Address	C_IO_HIGHADDR	0x00000000
I/O Module IO Bus Address Decode Mask	C_IO_MASK	0x00800000
LMB Address Bus Width	C_LMB_AWIDTH	32
LMB Data Bus Width	C_LMB_DWIDTH	32
Enable Receiver	C_USE_UART_RX	0
Enable Transmitter	C_USE_UART_TX	0
Define Baud Rate	C_UART_BAUDRATE	9600
Programmable Baud Rate	C_UART_PROG_BAUDRATE	0
Number of Data Bits	C_UART_DATA_BITS	8
Use Parity	C_UART_USE_PARITY	0
Even or Odd Parity	C_UART_ODD_PARITY	0
Implement Receive Interrupt	C_UART_RX_INTERRUPT	0
Implement Transmit Interrupt	C_UART_TX_INTERRUPT	0
Implement Error Interrupt	C_UART_ERROR_INTERRUPT	0
Use FIT	C_USE_FITn ⁽¹⁾	0
Number of Clocks Between Strokes	C_FITn_No_CLOCKS ⁽¹⁾	6216
Generate Interrupt	C_FITn_INTERRUPT ⁽¹⁾	0
Use PIT	C_USE_PITn ⁽¹⁾	0
Number of Bits for Timer	C_PITn_SIZE ⁽¹⁾	32
Shall Counter Value Be Readable	C_PITn_READABLE ⁽¹⁾	1
Define Prescaler	C_PITn_PRESCALER ⁽¹⁾	0
Generate Interrupt	C_PITn_INTERRUPT ⁽¹⁾	0
Use GPO	C_USE_GPOn ⁽¹⁾	0
Number of Bits	C_GPOn_SIZE ⁽¹⁾	32
Initial Value of GPO	C_GPOn_INIT ⁽¹⁾	0x00000000
Use GPI	C_USE_GPIIn ⁽¹⁾	0
Number of Bits	C_GPIIn_SIZE ⁽¹⁾	32
Generate Interrupt	C_GPIIn_INTERRUPT ⁽¹⁾	0
Use External Interrupts	C_INTC_USE_EXT_INTERRUPT	0
Number of External Inputs	C_INTC_INTR_SIZE	1
Level or Edge External Interrupts	C_INTC_LEVEL_EDGE	0x0000
Positive or Negative External Interrupts	C_INTC_POSITIVE	0xFFFF
Use Low-latency Interrupt Handling	C_INTR_HAS_FAST	0
Interrupt Output Connection	C_INTC_IRQ_CONNECTION	0
Use Triple Modular Redundancy	C_TMR	0
Activate TMR Disable Input	C_USE_TMR_DISABLE	0

Notes:

1. n = 1-4

Output Generation

For details, see the *Vivado Design Suite User Guide: Designing with IP* (UG896) [Ref 5].

Constraining the Core

This section contains information about constraining the core in the Vivado Design Suite.

Required Constraints

This section is not applicable for this IP core.

Device, Package, and Speed Grade Selections

This section is not applicable for this IP core.

Clock Frequencies

This section is not applicable for this IP core.

Clock Management

The I/O Module core is fully synchronous with all clocked elements clocked by the C1k input.

To operate properly when connected to MicroBlaze™, the C1k must be the same as the MicroBlaze C1k.

Clock Placement

This section is not applicable for this IP core.

Banking

This section is not applicable for this IP core.

Transceiver Placement

This section is not applicable for this IP core.

I/O Standard and Placement

This section is not applicable for this IP core.

Simulation

For comprehensive information about Vivado® simulation components, as well as information about using supported third party tools, see the *Vivado Design Suite User Guide: Logic Simulation* (UG900) [Ref 7].



IMPORTANT: For cores targeting 7 series or Zynq-7000 devices, UNIFAST libraries are not supported. Xilinx IP is tested and qualified with UNISIM libraries only.

Synthesis and Implementation

For details about synthesis and implementation, see the *Vivado Design Suite User Guide: Designing with IP* (UG896) [Ref 5].

Upgrading

For information on migrating from Xilinx ISE® Design Suite tools to the Vivado® Design Suite, see the *ISE to Vivado Design Suite Migration Guide* (UG911) [Ref 8].

Upgrade

This section describes changes that occur when upgrading from the previous version of the core.

The parameters, `USE_BOARD_FLOW`, `GPIO1_BOARD_INTERFACE`, `GPIO1_BOARD_INTERFACE`, `GPIO1_BOARD_INTERFACE`, and `UART_BOARD_INTERFACE` have been added in v2.1 of the core, to add support for board level constraints.

The parameters `C_INTC_USE_IRQ_OUT` and `C_INTC_IRQ_CONNECTION` have been added in v3.0 of the core, to provide additional interrupt output connection options.

The extra interrupt output port `INTC_IRQ_OUT` has been added in v3.0 of the core.

The parameters `C_TMR` and `C_USE_TMR_DISABLE` have been added in v3.1 of the core, to support Triple Modular Redundancy.

The additional ports `FromAVote`, `FromBVote`, `TMR_Disable`, `TMR_Rst`, and `ToVote` have been added in v3.1 of the core, to support Triple Modular Redundancy.

Debugging

This appendix includes details about resources available on the Xilinx Support website and debugging tools.

Finding Help on Xilinx.com

To help in the design and debug process when using the I/O Module, the [Xilinx Support web page](#) contains key resources such as product documentation, release notes, answer records, information about known issues, and links for obtaining further product support.

Documentation

This product guide is the main document associated with the I/O Module. This guide, along with documentation related to all products that aid in the design process, can be found on the [Xilinx Support web page](#) or by using the Xilinx® Documentation Navigator.

Download the Xilinx Documentation Navigator from the [Downloads page](#). For more information about this tool and the features available, open the online help after installation.

Answer Records

Answer Records include information about commonly encountered problems, helpful information on how to resolve these problems, and any known issues with a Xilinx product. Answer Records are created and maintained daily ensuring that users have access to the most accurate information available.

Answer Records for this core can be located by using the Search Support box on the main [Xilinx support web page](#). To maximize your search results, use proper keywords such as

- Product name
- Tool message(s)
- Summary of the issue encountered

A filter search is available after results are returned to further target the results.

Master Answer Record for the I/O Module Core

AR: [54445](#)

Technical Support

Xilinx provides technical support at the [Xilinx Support web page](#) for this LogiCORE™ IP product when used as described in the product documentation. Xilinx cannot guarantee timing, functionality, or support if you do any of the following:

- Implement the solution in devices that are not defined in the documentation.
- Customize the solution beyond that allowed in the product documentation.
- Change any section of the design labeled DO NOT MODIFY.

To contact Xilinx Technical Support, navigate to the [Xilinx Support web page](#).

Debug Tools

The main tool available to address I/O Module design issues is the Vivado® Design Suite debug feature.

Vivado Design Suite Debug Feature

The Vivado® Design Suite debug feature inserts logic analyzer and virtual I/O cores directly into your design. The debug feature also allows you to set trigger conditions to capture application and integrated block port signals in hardware. Captured signals can then be analyzed. This feature in the Vivado IDE is used for logic debugging and validation of a design running in Xilinx devices.

The Vivado logic analyzer is used to interact with the logic debug IP cores, including:

- ILA 2.0 (and later versions)
- VIO 2.0 (and later versions)

See the *Vivado Design Suite User Guide: Programming and Debugging* (UG908) [\[Ref 9\]](#).

Reference Boards

All 7 series Xilinx development boards support the I/O Module core. These boards can be used to prototype designs and establish that the core can communicate with the system.

Simulation Debug

The simulation debug flow for Mentor Graphics Questa Simulator (QuestaSim) is described below. A similar approach can be used with other simulators.

- Check for the latest supported versions of QuestaSim in the [Xilinx Design Tools: Release Notes Guide](#). Is this version being used? If not, update to this version.
- If using Verilog, do you have a mixed mode simulation license? If not, obtain a mixed-mode license.
- Ensure that the proper libraries are compiled and mapped. In the Vivado Design Suite **Flow > Simulation Settings** can be used to define the libraries.
- Have you associated the intended software program for the MicroBlaze processor with the simulation? Use the command **Tools > Associate ELF Files** in the Vivado Design Suite.
- When observing the traffic on the LMB interface connected to the LMB BRAM I/F Controller, see the *MicroBlaze Processor Reference Guide* (UG984) [\[Ref 1\]](#) for the LMB timing.

Hardware Debug

This section provides debug steps for common issues. The Vivado Design Suite debug feature is a valuable resource to use in hardware debug. The signal names mentioned in the following individual sections can be probed using the debug feature to debug specific problems.

General Checks

Ensure that all the timing constraints for the core were properly incorporated from the example design and that all constraints were met during implementation.

- Does it work in post-place and route timing simulation? If problems are seen in hardware but not in timing simulation, this could indicate a PCB issue. Ensure that all clock sources are active and clean.
- If using MMCMs in the design, ensure that all MMCMs have obtained lock by monitoring the `locked` port.

LMB Checks

To monitor the LMB interface, the signals `LMB_ABus`, `LMB_WriteDBus`, `LMB_ReadStrobe`, `LMB_AddrStrobe`, `LMB_WriteStrobe`, `LMB_BE`, `S1_DBus`, and `S1_Ready` can be connected to the Vivado debug feature.

To sample the interface signals, the Vivado debug feature should use the `Clk` clock signal.

Application Software Development

Device Drivers

The I/O Module core is supported by the IO Module driver, included with the Xilinx Software Development Kit.

Additional Resources and Legal Notices

Xilinx Resources

For support resources such as Answers, Documentation, Downloads, and Forums, see [Xilinx Support](#).

References

These documents provide supplemental material useful with this user guide:

1. *MicroBlaze Processor Reference Guide* ([UG984](#))
2. *7 Series FPGAs Configuration User Guide* ([UG470](#))
3. *Triple Modular Redundancy (TMR)* ([PG268](#))
4. *Vivado Design Suite User Guide: Designing IP Subsystems using IP Integrator* ([UG994](#))
5. *Vivado Design Suite User Guide: Designing with IP* ([UG896](#))
6. *Vivado Design Suite User Guide: Getting Started* ([UG910](#))
7. *Vivado Design Suite User Guide: Logic Simulation* ([UG900](#))
8. *ISE to Vivado Design Suite Migration Guide* ([UG911](#))
9. *Vivado Design Suite User Guide: Programming and Debugging* ([UG908](#))

Revision History

The following table shows the revision history for this document.

Date	Version	Revision
12/20/2017	3.1	<ul style="list-style-type: none"> Corrected PIT register description.
04/05/2017	3.1	<ul style="list-style-type: none"> Added Triple Modular Redundancy (TMR) functionality.
04/06/2016	3.0	<ul style="list-style-type: none"> Updated with description of extended addressing. Allow selection of single interrupt output interface.
11/18/2015	3.0	Added support for UltraScale+ families.
06/24/2015	3.0	<ul style="list-style-type: none"> Moved performance and resource utilization data to the web. Clarified PIT timer behavior.
10/01/2014	3.0	Updated due to core version change.
12/18/2013	2.2	<ul style="list-style-type: none"> Synchronization flip-flops added on asynchronous interrupt inputs. UltraScale™ architecture support added.
10/02/2013	2.1	<ul style="list-style-type: none"> Revision number advanced to 2.1 to align with core version number 2.1. Added description of board interfaces.
03/20/2013	1.0	This Product Guide replaces PG052. There are no documentation changes for this release.

Please Read: Important Legal Notices

The information disclosed to you hereunder (the "Materials") is provided solely for the selection and use of Xilinx products. To the maximum extent permitted by applicable law: (1) Materials are made available "AS IS" and with all faults, Xilinx hereby DISCLAIMS ALL WARRANTIES AND CONDITIONS, EXPRESS, IMPLIED, OR STATUTORY, INCLUDING BUT NOT LIMITED TO WARRANTIES OF MERCHANTABILITY, NON-INFRINGEMENT, OR FITNESS FOR ANY PARTICULAR PURPOSE; and (2) Xilinx shall not be liable (whether in contract or tort, including negligence, or under any other theory of liability) for any loss or damage of any kind or nature related to, arising under, or in connection with, the Materials (including your use of the Materials), including for any direct, indirect, special, incidental, or consequential loss or damage (including loss of data, profits, goodwill, or any type of loss or damage suffered as a result of any action brought by a third party) even if such damage or loss was reasonably foreseeable or Xilinx had been advised of the possibility of the same. Xilinx assumes no obligation to correct any errors contained in the Materials or to notify you of updates to the Materials or to product specifications. You may not reproduce, modify, distribute, or publicly display the Materials without prior written consent. Certain products are subject to the terms and conditions of Xilinx's limited warranty, please refer to Xilinx's Terms of Sale which can be viewed at <https://www.xilinx.com/legal.htm#tos>; IP cores may be subject to warranty and support terms contained in a license issued to you by Xilinx. Xilinx products are not designed or intended to be fail-safe or for use in any application requiring fail-safe performance; you assume sole risk and liability for use of Xilinx products in such critical applications, please refer to Xilinx's Terms of Sale which can be viewed at <https://www.xilinx.com/legal.htm#tos>.

AUTOMOTIVE APPLICATIONS DISCLAIMER

AUTOMOTIVE PRODUCTS (IDENTIFIED AS "XA" IN THE PART NUMBER) ARE NOT WARRANTED FOR USE IN THE DEPLOYMENT OF AIRBAGS OR FOR USE IN APPLICATIONS THAT AFFECT CONTROL OF A VEHICLE ("SAFETY APPLICATION") UNLESS THERE IS A SAFETY CONCEPT OR REDUNDANCY FEATURE CONSISTENT WITH THE ISO 26262 AUTOMOTIVE SAFETY STANDARD ("SAFETY DESIGN"). CUSTOMER SHALL, PRIOR TO USING OR DISTRIBUTING ANY SYSTEMS THAT INCORPORATE PRODUCTS, THOROUGHLY TEST SUCH SYSTEMS FOR SAFETY PURPOSES. USE OF PRODUCTS IN A SAFETY APPLICATION WITHOUT A SAFETY DESIGN IS FULLY AT THE RISK OF CUSTOMER, SUBJECT ONLY TO APPLICABLE LAWS AND REGULATIONS GOVERNING LIMITATIONS ON PRODUCT LIABILITY.

© Copyright 2013–2017 Xilinx, Inc. Xilinx, the Xilinx logo, Artix, ISE, Kintex, Spartan, Virtex, Vivado, Zynq, and other designated brands included herein are trademarks of Xilinx in the United States and other countries. All other trademarks are the property of their respective owners.